



US00D717443S

(12) **United States Design Patent**
Hughes et al.

(10) **Patent No.:** **US D717,443 S**

(45) **Date of Patent:** **** Nov. 11, 2014**

- (54) **EAR WORN SENSOR DEVICE**
- (71) Applicants: **Darran Hughes**, Dublin (IE); **Cian O’Sullivan**, Limerick (IE)
- (72) Inventors: **Darran Hughes**, Dublin (IE); **Cian O’Sullivan**, Limerick (IE)
- (73) Assignee: **Zinc Software Ltd.**, Dublin (IE)
- (**) Term: **14 Years**

2004/0054291 A1*	3/2004	Schulz et al.	600/500
2007/0219457 A1*	9/2007	Lo	600/519
2009/0281435 A1*	11/2009	Ahmed et al.	600/502
2010/0113948 A1*	5/2010	Yang et al.	600/500

* cited by examiner

Primary Examiner — Anhdao Doan
(74) *Attorney, Agent, or Firm* — Soquel Group LLC

(57) **CLAIM**

The ornamental design for an ear worn sensor device, as shown and described.

DESCRIPTION

This Application is related to co-pending U.S. Design patent application Ser. No. 29/407,276, filed on Nov. 27, 20011, and entitled “Ear Worn Heart Sensor Device.”

FIG. 1 is a front isometric view of an ear worn sensor device showing our new design;

FIG. 2 is a rear isometric view thereof;

FIG. 3 is a side elevation view view thereof;

FIG. 4 is a front elevation view thereof;

FIG. 5 is a rear elevation view thereof;

FIG. 6 is a top view thereof;

FIG. 7 is a front isometric view of another embodiment of an ear worn sensor device showing our new design;

FIG. 8 is a rear isometric view thereof;

FIG. 9 is a side elevation view view thereof;

FIG. 10 is a front elevation view thereof;

FIG. 11 is a rear elevation view thereof; and,

FIG. 12 is a top view thereof.

The broken lines in the drawings are included for the purpose of illustrating portions of the ear worn sensor device that form no part of the claimed design.

- (21) Appl. No.: **29/460,916**
 - (22) Filed: **Jul. 16, 2013**
 - (51) **LOC (10) Cl.** **24-01**
 - (52) **U.S. Cl.**
USPC **D24/167; D24/174**
 - (58) **Field of Classification Search**
USPC D24/165–168, 107, 186, 187, 173–175;
D10/38, 46, 78, 98; 600/301, 382, 390,
600/483, 500–503, 508, 509, 513;
D14/205, 206, 223–226, 249;
381/23.1, 312, 322–324, 328, 330,
381/380, 381; 181/135
- See application file for complete search history.

(56) **References Cited**

U.S. PATENT DOCUMENTS

4,334,544 A *	6/1982	Hill et al.	600/473
D273,706 S *	5/1984	McCall	D24/174
D585,557 S *	1/2009	Sakurai et al.	D24/187
D589,152 S *	3/2009	Champkins	D24/187
D692,142 S *	10/2013	Hughes et al.	D24/167

1 Claim, 12 Drawing Sheets

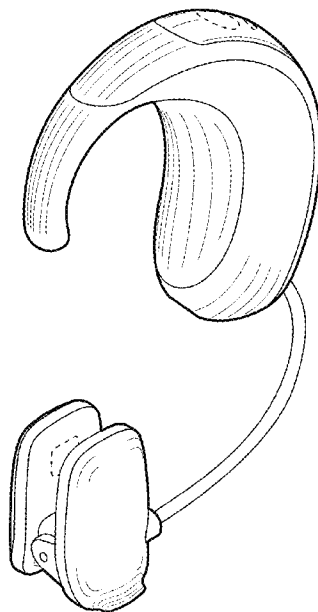

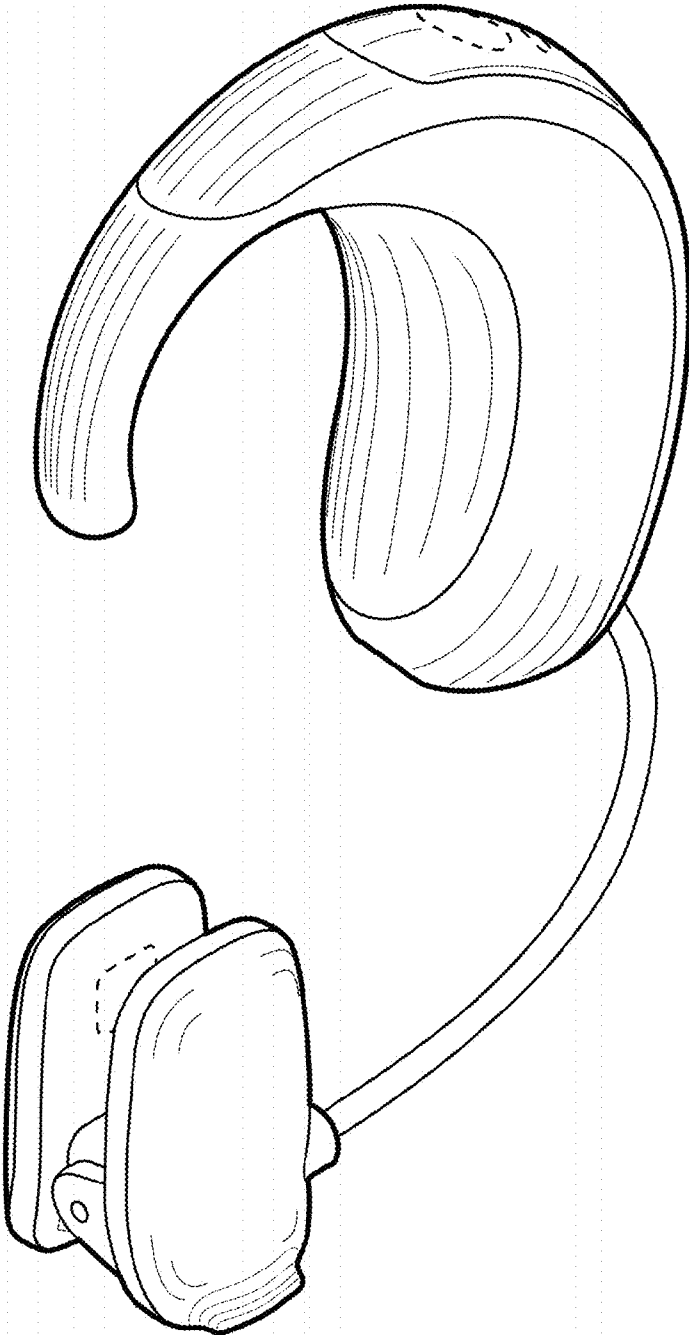

FIG. 1

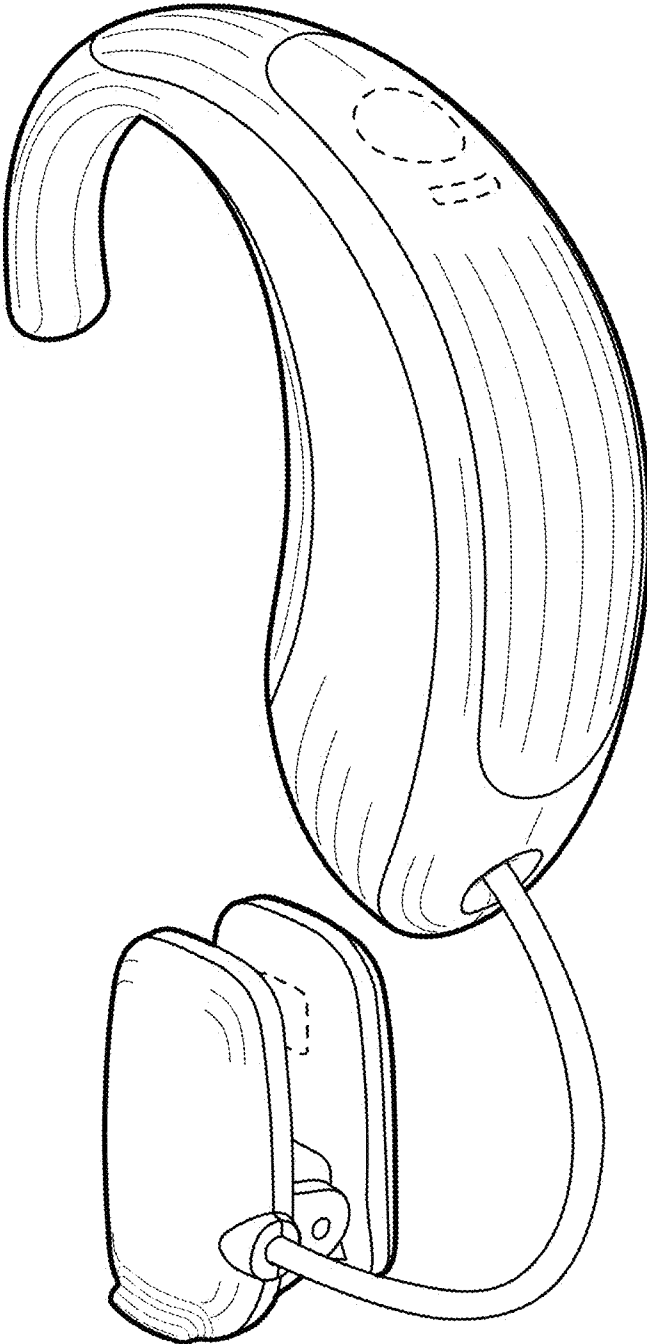

FIG. 2

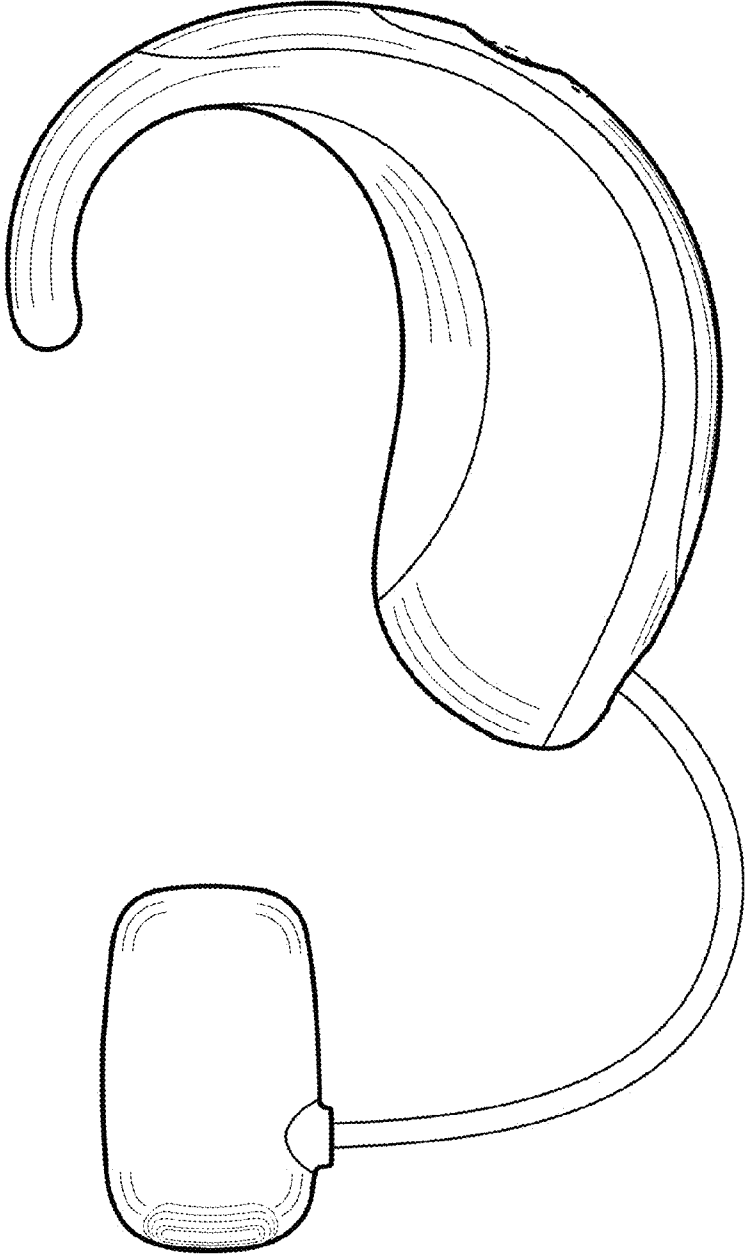

FIG. 3

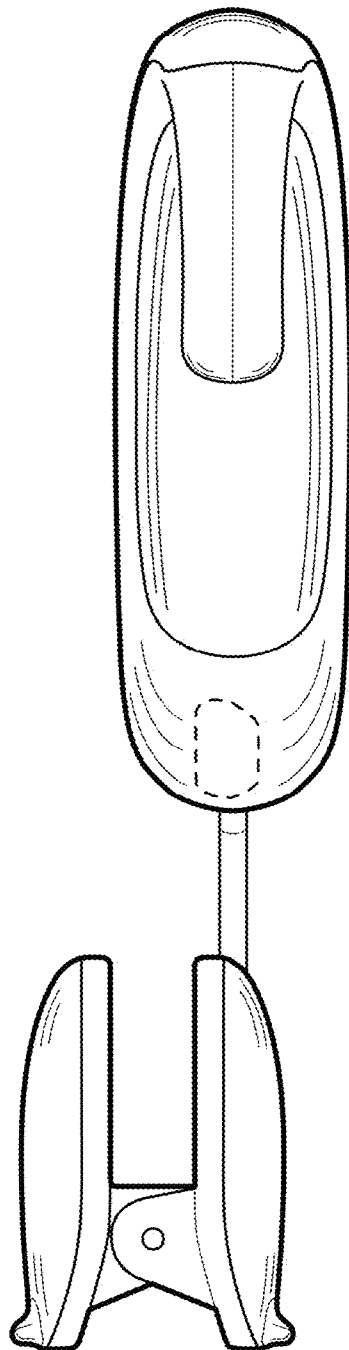

FIG. 4

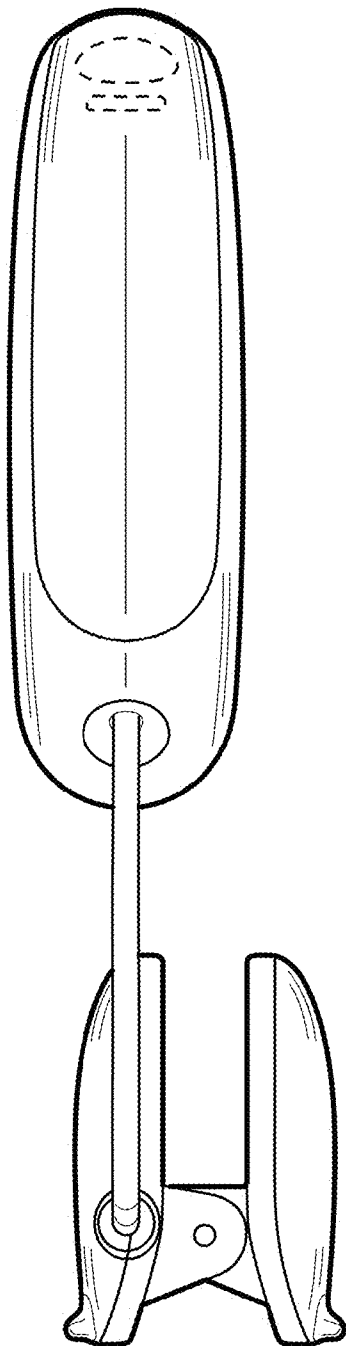

FIG. 5

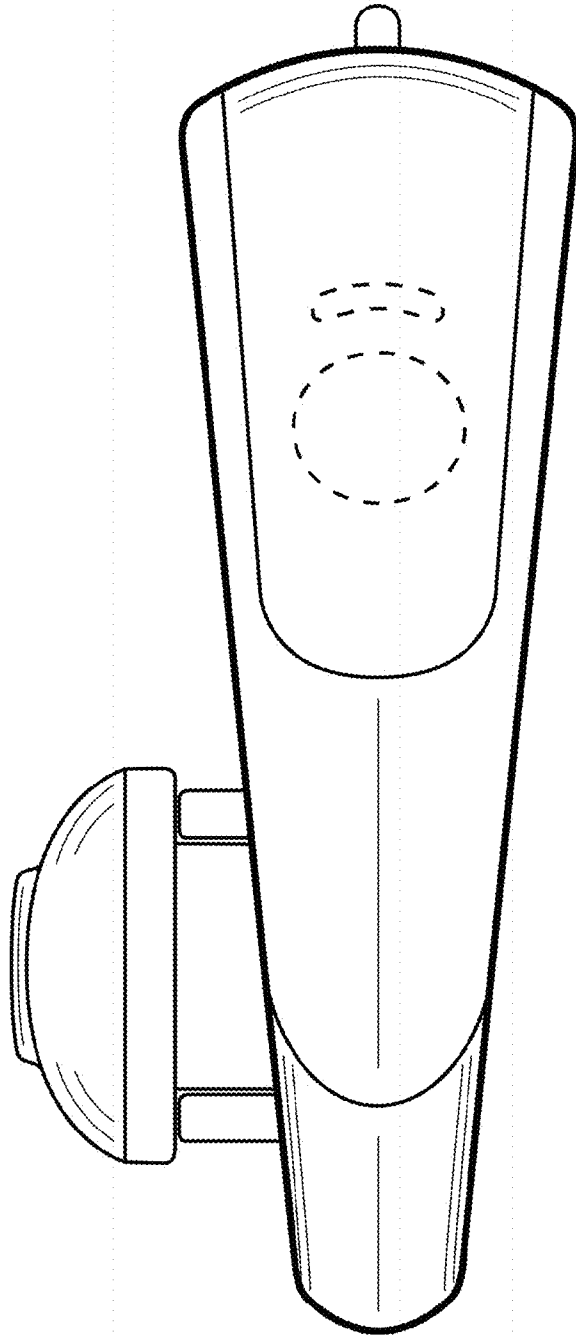

FIG. 6

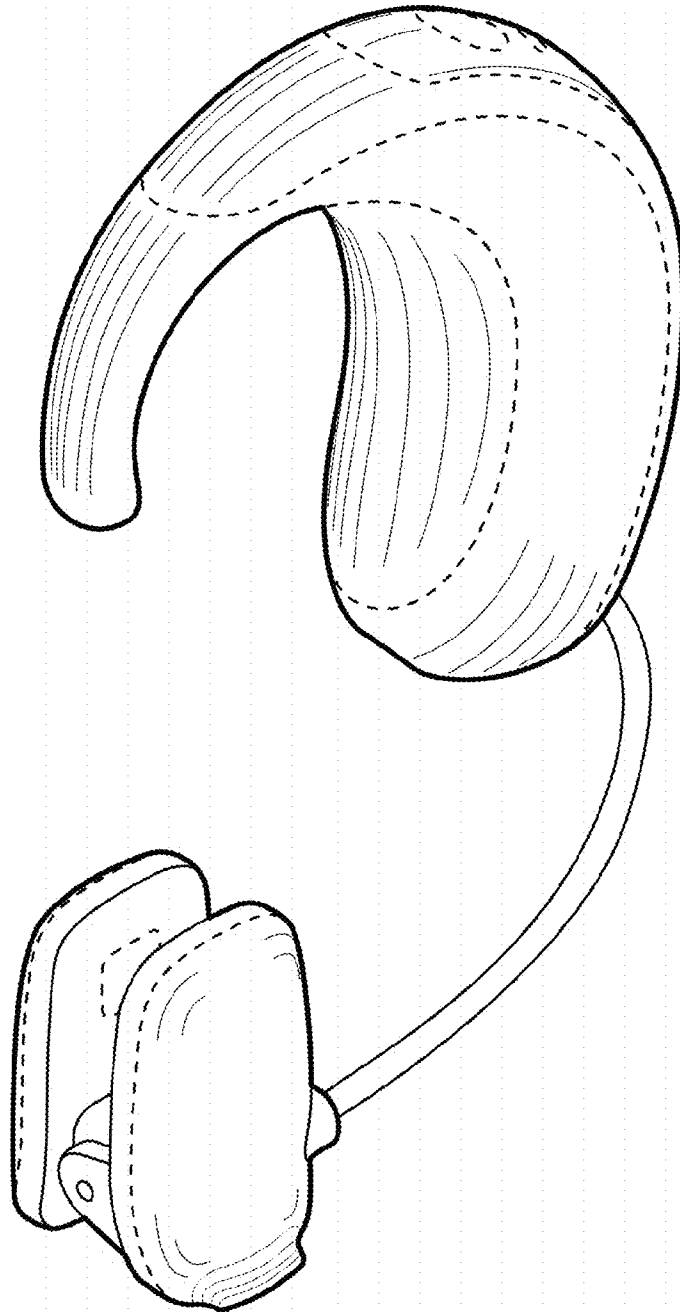

FIG. 7

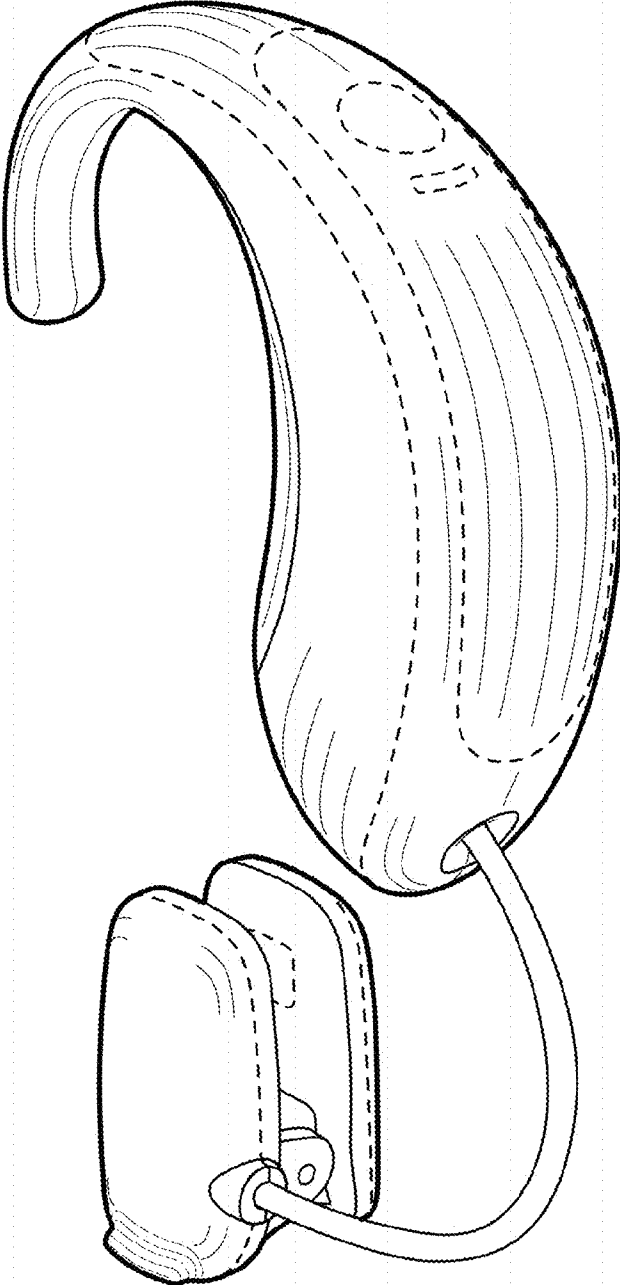

FIG. 8

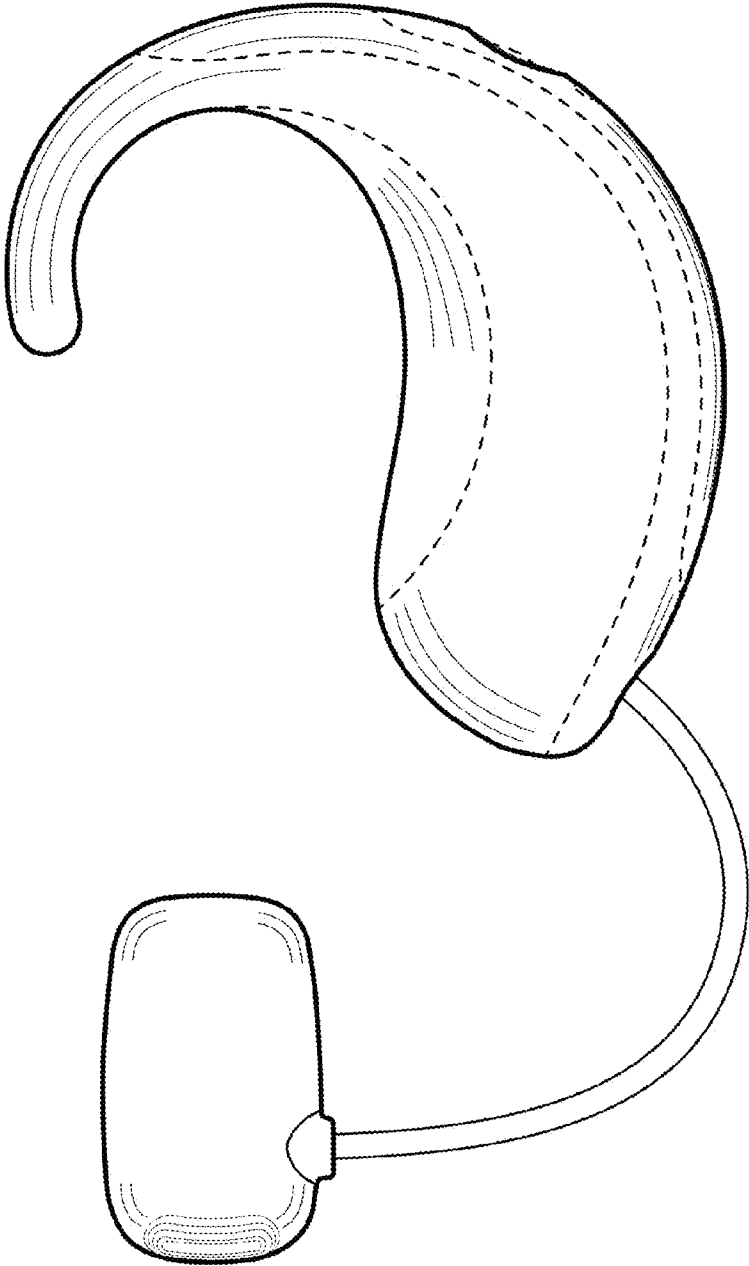

FIG. 9

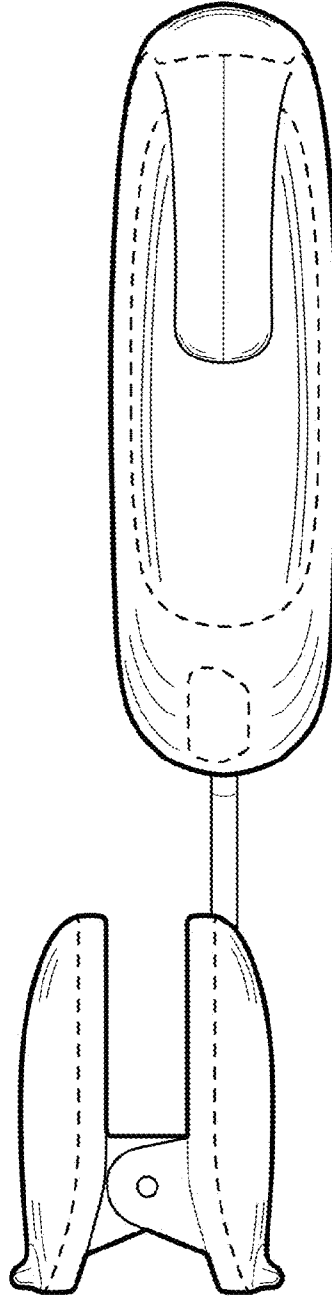

FIG. 10

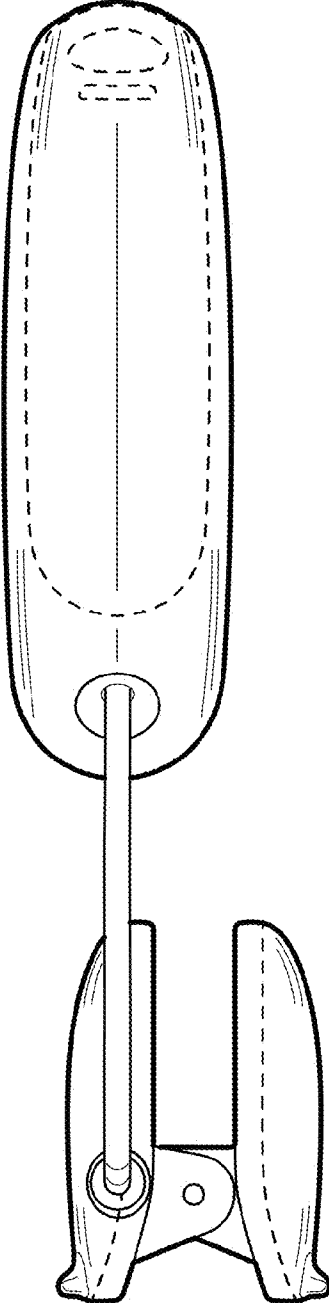

FIG. 11

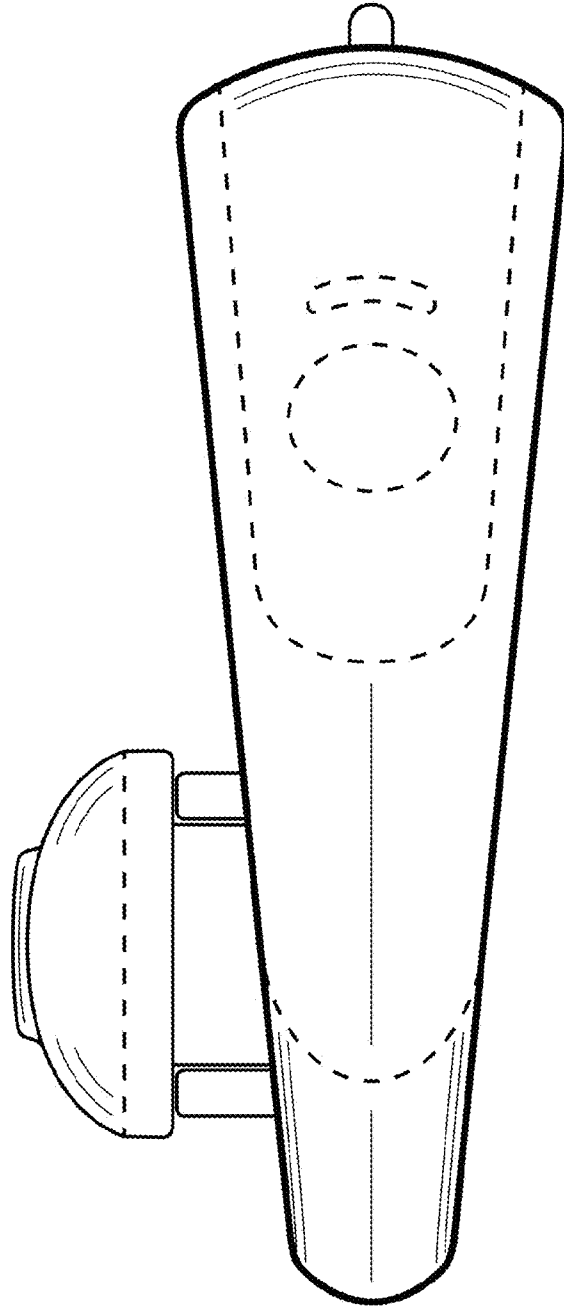

FIG. 12