



US008451127B2

(12) **United States Patent**  
**Bychkov et al.**

(10) **Patent No.:** **US 8,451,127 B2**  
(45) **Date of Patent:** **\*May 28, 2013**

(54) **JACKET LOCATOR**

(56) **References Cited**

(75) Inventors: **Eyal Bychkov**, Hod Hasharon (IL); **Tal Engelstein**, Ramat Gan (IL); **Yair Leshem**, Tel Aviv (IL); **Uri Ron**, Tel Aviv (IL); **Ron Levy**, Savyon (IL); **Hagit Perry**, Herzilya (IL)

(73) Assignee: **Google Inc.**, Mountain View, CA (US)

(\* ) Notice: Subject to any disclaimer, the term of this patent is extended or adjusted under 35 U.S.C. 154(b) by 0 days.

This patent is subject to a terminal disclaimer.

(21) Appl. No.: **13/567,057**

(22) Filed: **Aug. 5, 2012**

(65) **Prior Publication Data**

US 2012/0306647 A1 Dec. 6, 2012

**Related U.S. Application Data**

(63) Continuation of application No. 12/476,261, filed on Jun. 2, 2009, now Pat. No. 8,258,960.

(60) Provisional application No. 61/130,784, filed on Jun. 2, 2008.

(51) **Int. Cl.**  
**G08B 13/14** (2006.01)

(52) **U.S. Cl.**  
USPC ..... **340/572.8**; 340/539.13; 340/539.32;  
455/414.2; 455/456.1; 455/556.1

(58) **Field of Classification Search**  
USPC ..... 340/572.8, 539.13, 539.32, 568.1,  
340/568.7, 571; 455/414.2, 456.1, 556.1,  
455/575.1, 90.3, 558, 557, 426.1, 550.1;  
379/433.11

See application file for complete search history.

U.S. PATENT DOCUMENTS

5,625,673	A	4/1997	Grewe et al.
5,628,055	A	5/1997	Stein
5,809,115	A	9/1998	Inkinen
5,893,037	A	4/1999	Reele et al.
5,907,815	A	5/1999	Grimm et al.
6,188,917	B1	2/2001	Laurenti
6,201,867	B1	3/2001	Koike
6,243,578	B1	6/2001	Koike
6,477,357	B1	11/2002	Cook

(Continued)

FOREIGN PATENT DOCUMENTS

EP	1871075	A1	12/2007
GB	2438448	A1	11/2007

(Continued)

Primary Examiner — Brent Swarthout

(74) Attorney, Agent, or Firm — Soquel Group LLC

(57) **ABSTRACT**

A locator system for electronic devices including at least one jacket for a modular wireless communicator, each jacket having an identifier, and a modular wireless communicator that attaches to each one of the at least one jacket, including a positioning system for identifying a location of the modular wireless communicator, a log manager for recording a plurality of entries in a log, each entry including the jacket identifier for a jacket currently attached to the modular wireless communicator, and a current location as identified by the positioning system, and a controller for notifying the log manager of occurrence of a log trigger event, wherein the log manager records a new entry in the log when it receives a notification of a log trigger event from the controller, and wherein the log trigger events enable determination of a location where a jacket was last actively used with the modular wireless communicator.

**20 Claims, 7 Drawing Sheets**

**100**

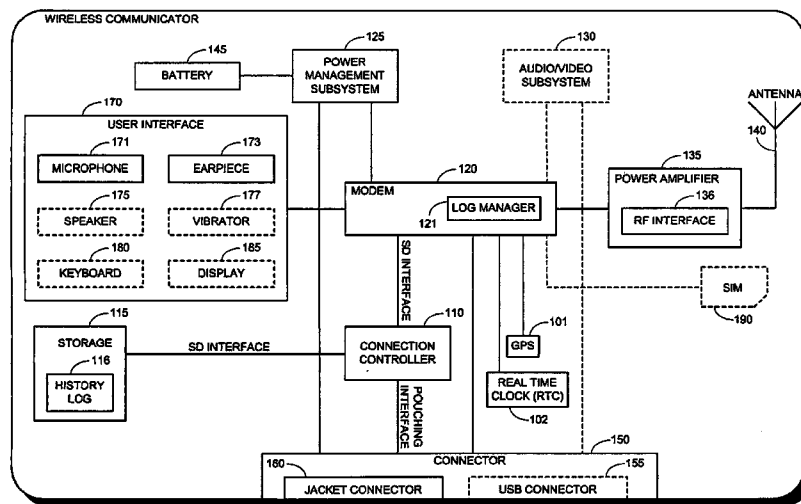

U.S. PATENT DOCUMENTS

6,516,202 B1 2/2003 Hawkins et al.  
 6,640,113 B1 10/2003 Shim et al.  
 6,690,947 B1 2/2004 Tom  
 6,898,283 B2 5/2005 Wycherley et al.  
 6,907,264 B1 6/2005 Sterkel  
 6,999,792 B2 2/2006 Warren  
 7,085,542 B2 8/2006 Dietrich et al.  
 7,194,285 B2 3/2007 Tom  
 7,266,391 B2 9/2007 Warren  
 7,400,884 B2 7/2008 Fok et al.  
 7,477,919 B2 1/2009 Warren  
 7,515,937 B2 4/2009 Lee  
 8,258,960 B2 \* 9/2012 Bychkov et al. .... 340/572.8  
 2002/0090980 A1 7/2002 Wilcox et al.  
 2002/0151327 A1 10/2002 Levitt  
 2004/0233930 A1 11/2004 Colby, Jr.  
 2004/0268005 A1 12/2004 Dickie  
 2005/0159184 A1 7/2005 Kerner et al.  
 2006/0003804 A1 1/2006 Liu  
 2006/0105722 A1 5/2006 Kumar  
 2006/0190321 A1 8/2006 Martins Nicho et al.  
 2006/0241353 A1 10/2006 Makino et al.

2007/0004450 A1 1/2007 Parikh  
 2007/0018957 A1 1/2007 Seo  
 2007/0079030 A1 4/2007 Okuley et al.  
 2007/0161404 A1 7/2007 Yasujima et al.  
 2007/0288583 A1 12/2007 Rensin et al.  
 2008/0009325 A1 1/2008 Zinn et al.  
 2008/0040354 A1 2/2008 Ray et al.  
 2008/0065315 A1 3/2008 Guy et al.  
 2008/0140886 A1 6/2008 Izutsu  
 2008/0157961 A1 7/2008 Park et al.  
 2008/0317456 A1 12/2008 Lee et al.  
 2009/0065578 A1 3/2009 Peterson et al.  
 2009/0324025 A1 12/2009 Camp, Jr. et al.  
 2009/0325599 A1 12/2009 Vuori  
 2010/0229101 A1 9/2010 Lagerstedt et al.

FOREIGN PATENT DOCUMENTS

WO 9421058 A1 9/1994  
 WO 0059247 A1 10/2000  
 WO 0186922 A1 11/2001  
 WO 03103174 A1 12/2003

\* cited by examiner

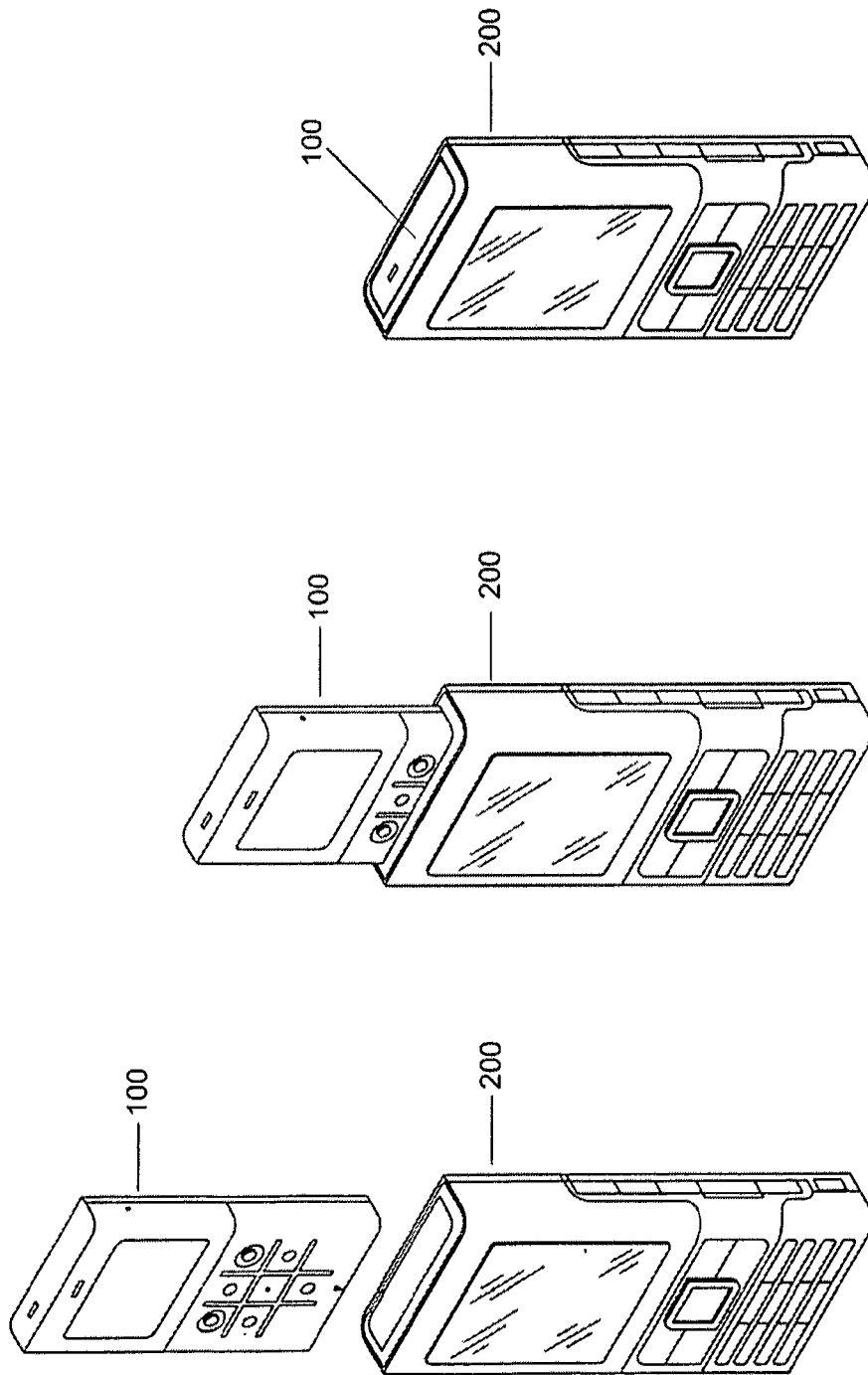

FIG. 1

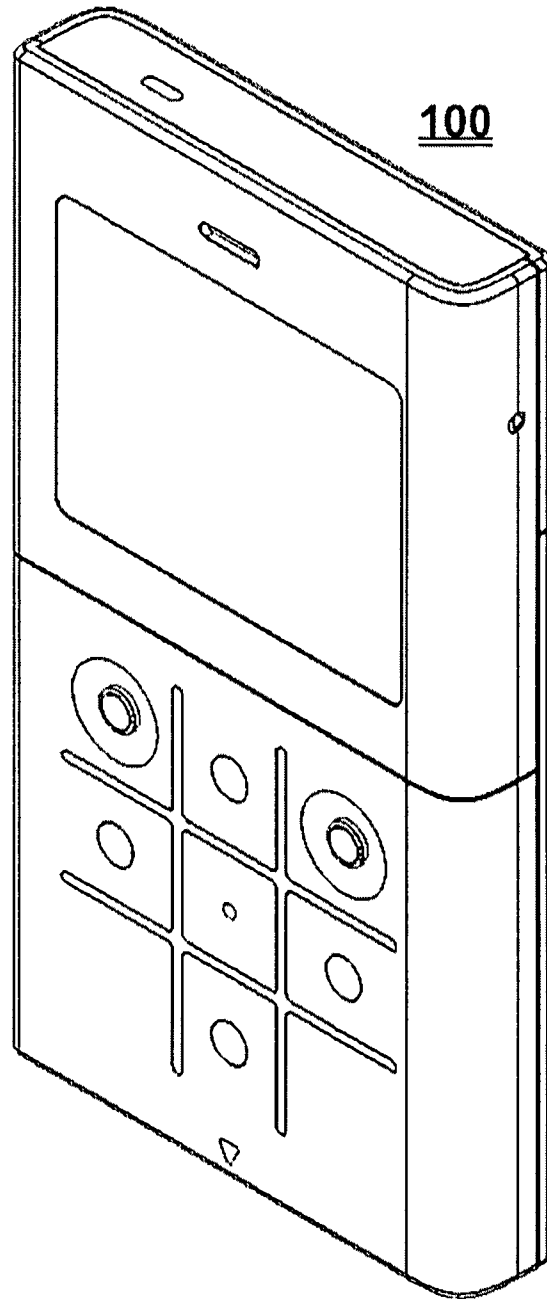

FIG. 2

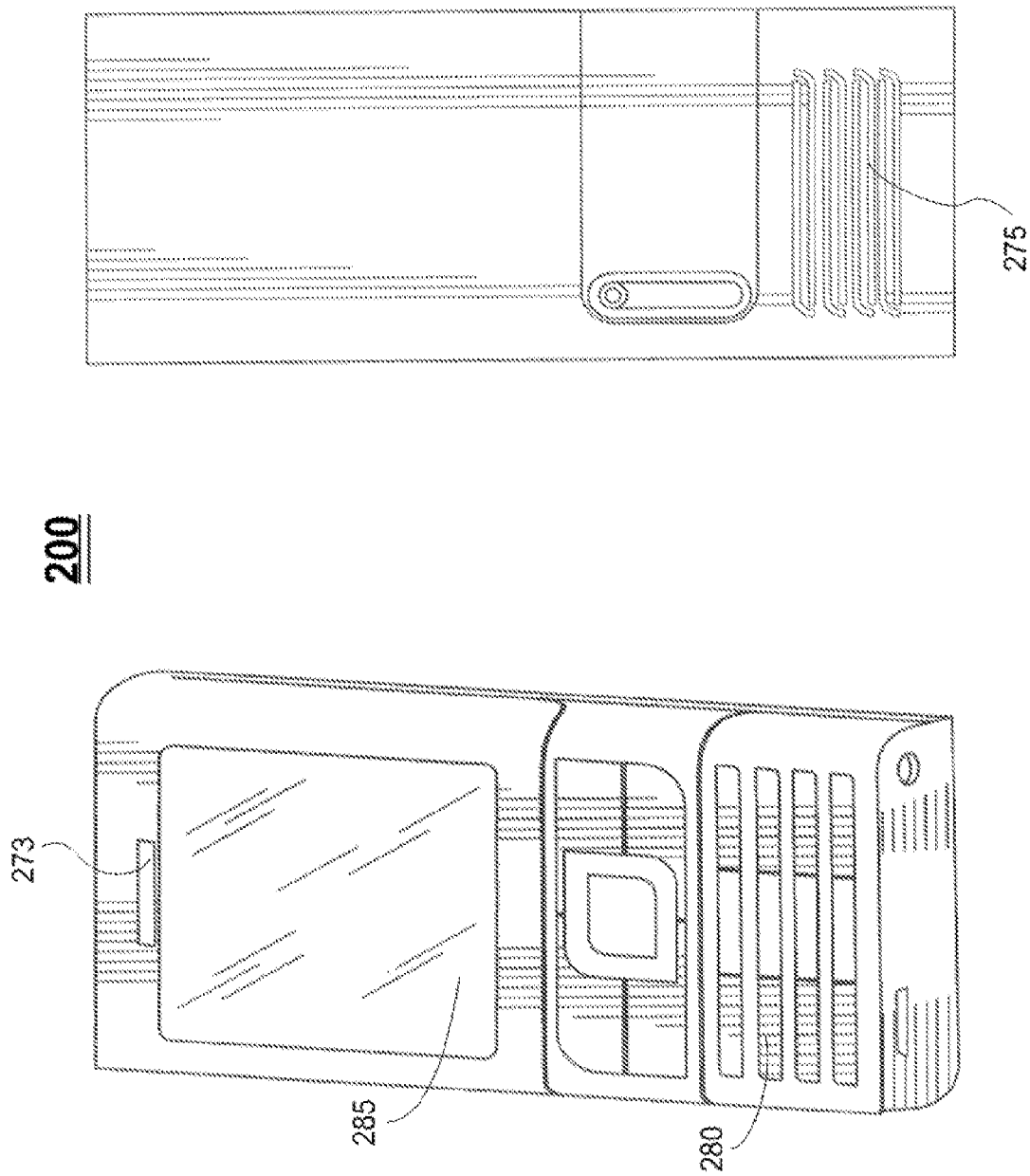

FIG. 3

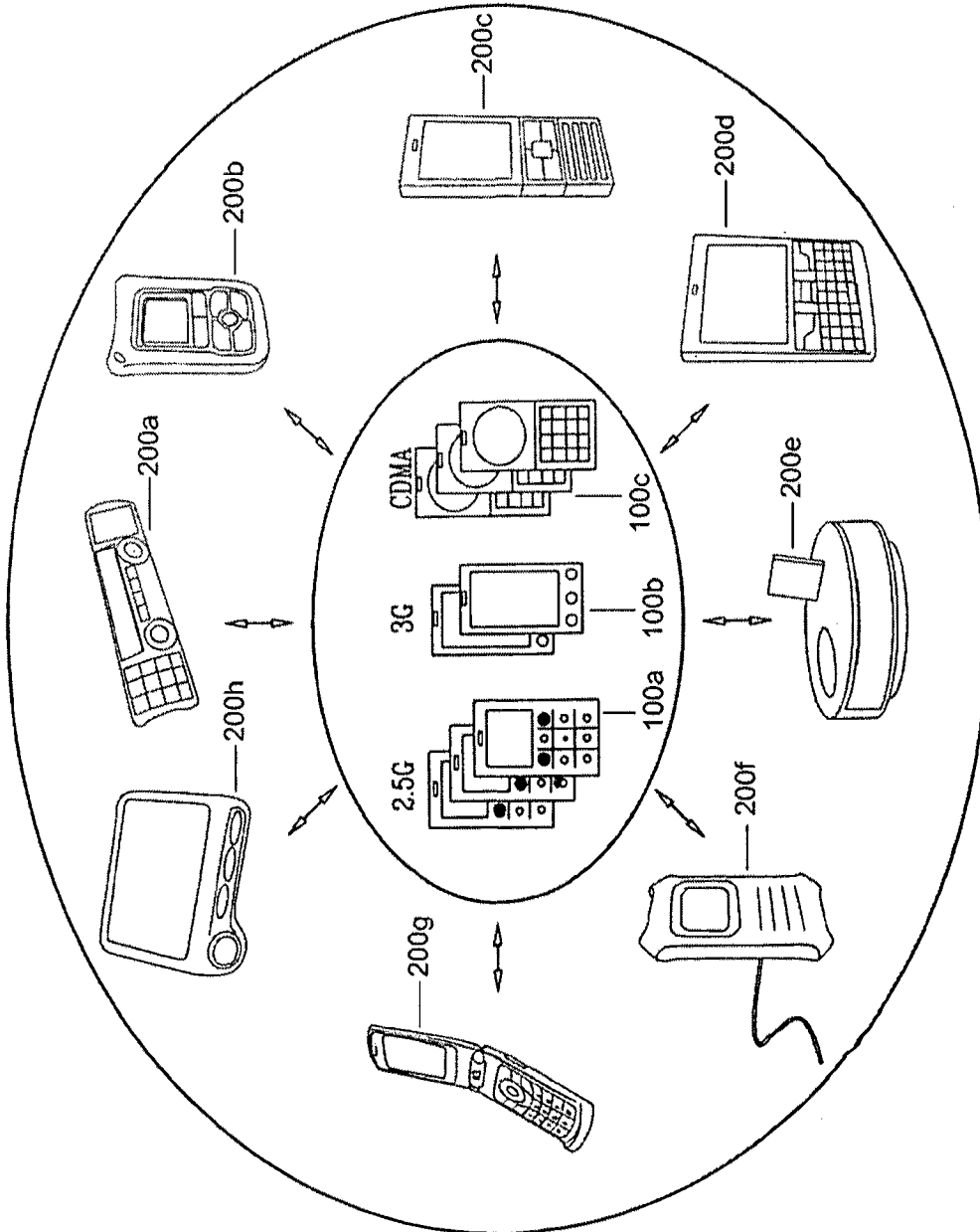

FIG. 4

100

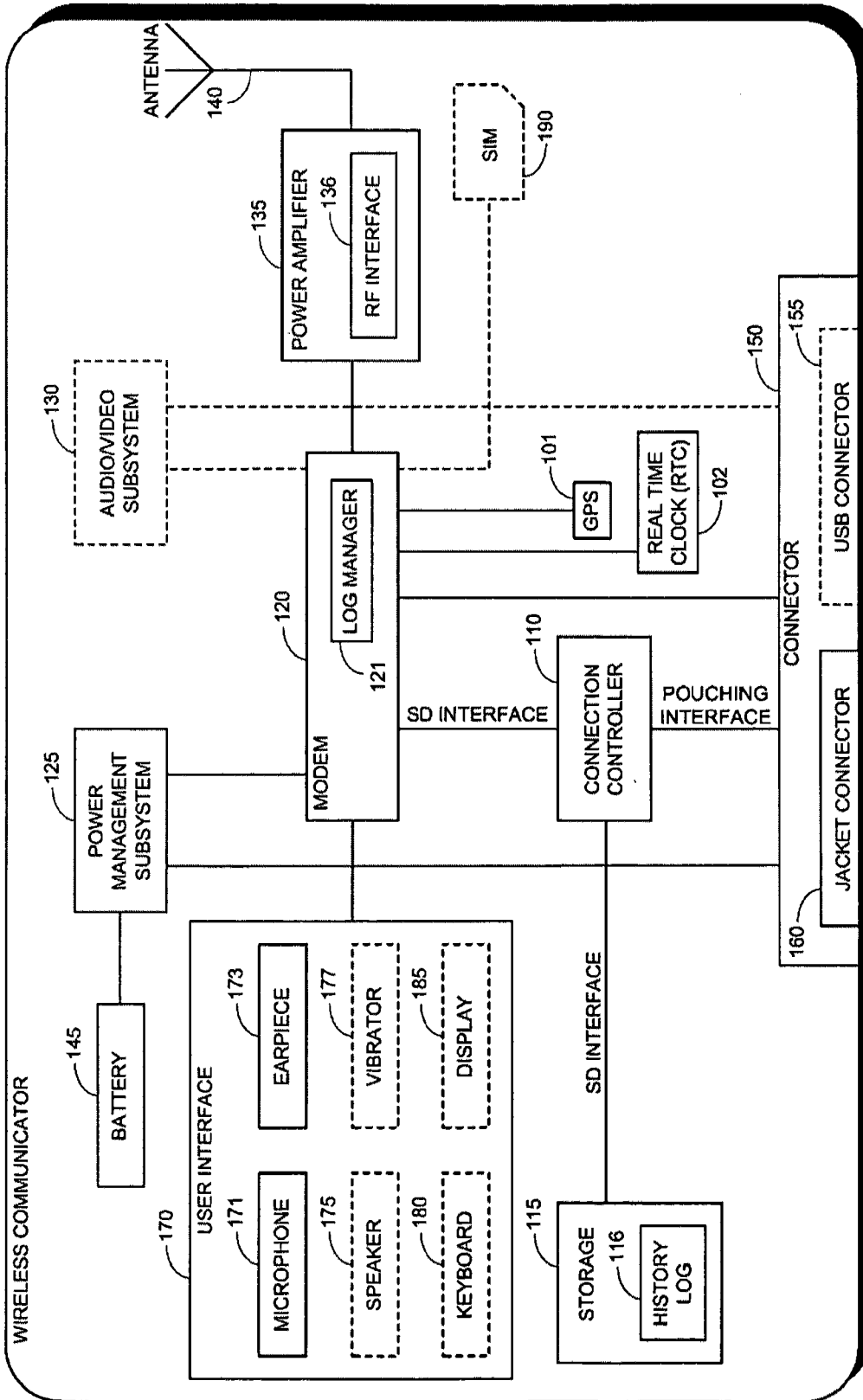
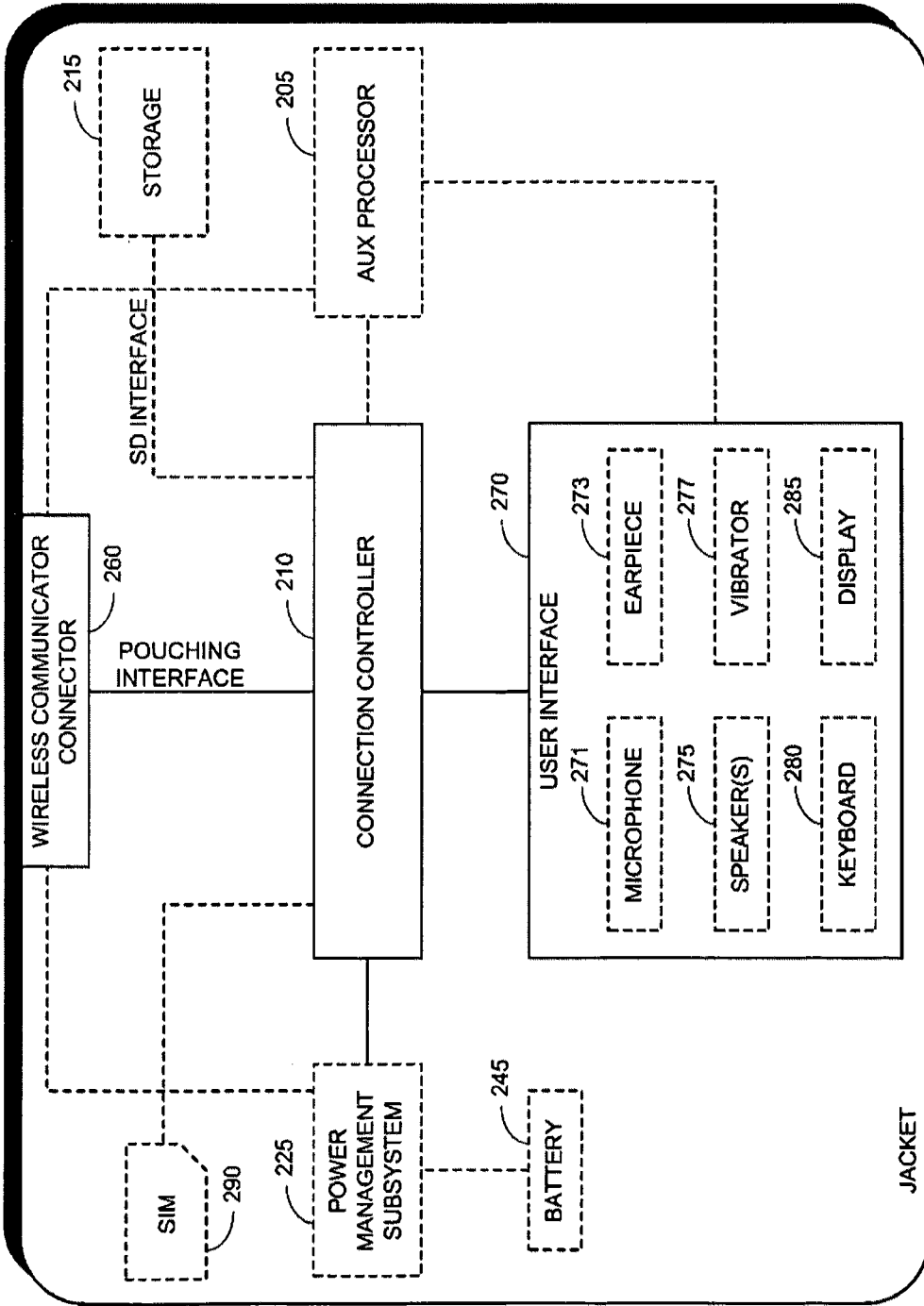

FIG. 5



200

FIG. 6



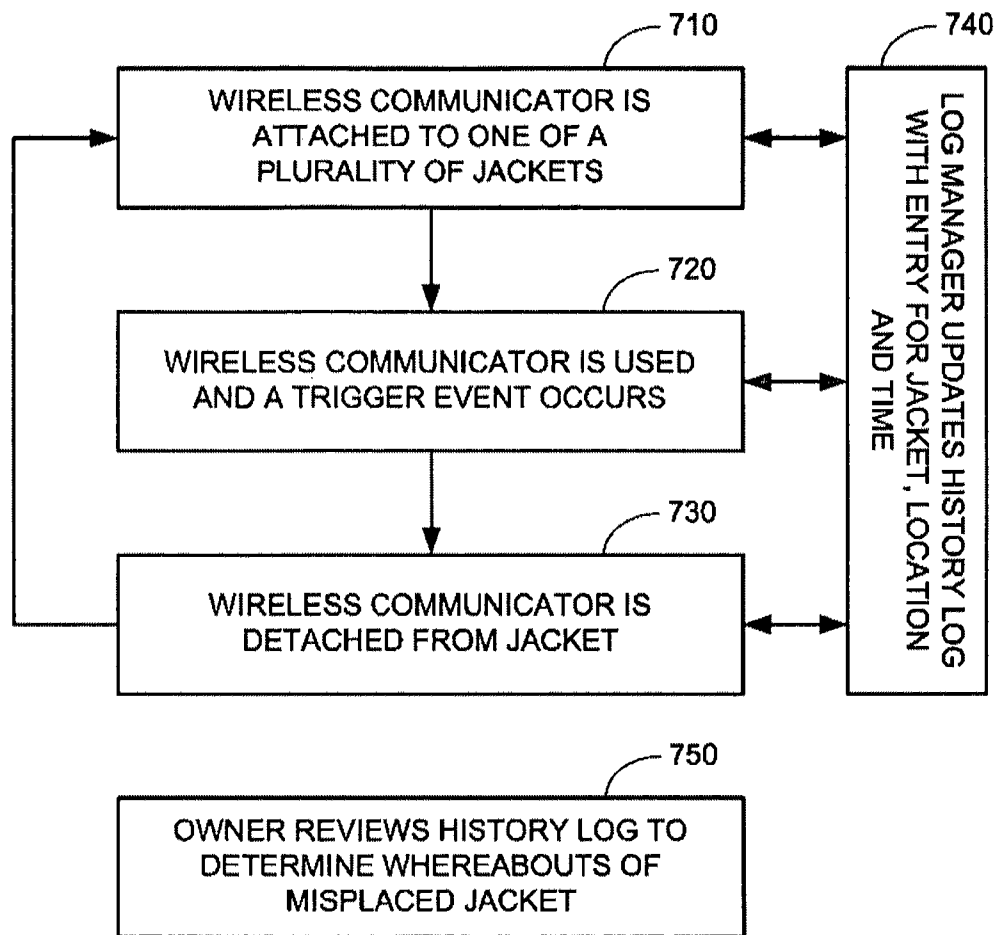

FIG. 7

**JACKET LOCATOR**PRIORITY REFERENCE TO RELATED  
APPLICATIONS

This application claims benefit of U.S. Provisional Application No. 61/130,784, entitled JACKET LOCATOR, filed on Jun. 2, 2008 by inventors Eyal Bychkov, Tal Engelstein, Yair Leshem, Uri Ron, Ron Levy and Hagit Perry.

## FIELD OF THE INVENTION

The field of the present invention is wireless communication.

## BACKGROUND OF THE INVENTION

With advances in miniaturization of electronic components, ever smaller consumer electronic devices are becoming available. Mobile phones, PDAs, cameras and media players are some examples of such devices. These and other devices have become so small that they fit inside a shirt pocket. As a result, people are tending to misplace these devices.

Various solutions have been proposed to locate misplaced electronic devices. One such solution uses sets of electronic locators, which are attached to the small devices. An example of such a locator is the KeyRinger™ manufactured by Sierra Systems of Oakland, Calif. When one of a set of KeyRingers is pressed, the other KeyRingers produce audible and visible indications, which enable an owner to find them.

Another such solution uses a transmitter and a receiver, where the receiver knows its distance from the transmitter. The transmitter is generally attached to a small device, and the receiver indicates to an owner when the distance between the receiver and the small device exceeds a predefined threshold.

A drawback with conventional solutions to locate misplaced devices is that the transmitters, which are attached to or embedded in the devices, require a power source, typically a battery. If the battery is not regularly replaced or recharged, then the transmitters fail.

It would thus be of advantage to have a locator for electronic devices that does not require transmitters attached to or embedded in the devices.

## SUMMARY OF THE DESCRIPTION

Aspects of the present invention provide a system and method for locating electronic devices, without the need for attaching or embedding transmitters to the devices.

Embodiments of the present invention relate to a modular wireless communicator that attaches to a plurality of electronic devices referred to herein as jackets. The wireless communicator enhances the jackets by providing them with wireless connectivity, and the jackets enhance the wireless communicator by providing electronics and interfaces. In an embodiment of the present invention, the wireless communicator has an embedded global positioning system (GPS). The GPS operates in conjunction with the wireless communicator so that at locations where GPS signals are weak or unavailable, such as indoors, the GPS uses cellular location sensing capabilities to determine position. An example of such an enhanced GPS is the eGPS® system manufactured by CSR plc of the United Kingdom.

The wireless communicator maintains a history log of the jackets to which it is attached, and the locations and times of attachment to and detachment from these jackets. The history log includes entries that record (i) a jacket identifier, (ii) a

GPS location, and (iii) a date & time. A history log manager adds new entries to the history log when log trigger events occur. Log trigger events include powering on/off of the wireless communicator, attaching/detaching the wireless communicator to/from a jacket, using the wireless communicator to dial a phone number, using the wireless communicator to send an SMS/MMS message, using the wireless communicator to play an audio/video file, and using the wireless communicator to browse a designated web site.

A user can view the history log on his wireless communicator in order to locate a jacket that he misplaced. Moreover the wireless communicator's GPS generates navigable directions to reach a designated one of any location recorded in the history log.

There is thus provided in accordance with an embodiment of the present invention a locator system for electronic devices including at least one jacket for a modular wireless communicator, each jacket having a unique identifier, and a modular wireless communicator that attaches to each one of the at least one jacket, including a positioning system for identifying a location of the wireless communicator, a clock for identifying a date & time, a log manager, coupled with the positioning system and with the clock, for recording a plurality of entries in a history log, each entry including (i) a jacket identifier, (ii) a location as identified by the positioning system, and (iii) a date & time as identified by the clock, and a controller coupled with the log manager for notifying the log manager of occurrence of a log trigger event, wherein the log manager records a new entry in the history log when it receives a notification of a log trigger event from the controller.

There is also provided in accordance with an embodiment of the present invention a locator method, including maintaining a history log for a wireless communicator that attaches to a plurality of jackets, each jacket having a unique identifier, the history log including a plurality of entries and each entry including (i) a jacket identifier, (ii) a location, and (iii) a date & time, monitoring the wireless communicator for detection of occurrence of a log trigger event, and in response to detection of occurrence of a log trigger event, adding a new entry to the history log.

## BRIEF DESCRIPTION OF THE DRAWINGS

The present invention will be more fully understood and appreciated from the following detailed description, taken in conjunction with the drawings in which:

FIG. 1 is an illustration of a wireless communicator being inserted into a jacket, in accordance with an embodiment of the present invention;

FIG. 2 is an illustration of the wireless communicator of FIG. 1, in accordance with an embodiment of the present invention;

FIG. 3 is an illustration of the jacket of FIG. 1, in accordance with an embodiment of the present invention;

FIG. 4 is an illustration of a plurality of wireless communicators and a plurality of jackets, whereby each wireless communicator may be attached to any of the jackets so as to operate in combination therewith, in accordance with an embodiment of the present invention;

FIG. 5 is a simplified block diagram of the wireless communicator of FIG. 1, in accordance with an embodiment of the present invention;

FIG. 6 is simplified block diagram of the jacket of FIG. 1, in accordance with an embodiment of the present invention; and

FIG. 7 is a simplified flowchart of a method for locating a misplaced jacket using a history log stored in the wireless communicator, in accordance with an embodiment of the present invention.

#### DETAILED DESCRIPTION

Aspects of the present invention relate to a small modular wireless communicator that connects to a plurality of other electronic devices and enables the other devices to communicate wirelessly. The modular wireless communicator of the present invention operates both in standalone mode as a wireless phone, and also in conjunction with devices to which it is connected.

The devices to which the wireless communicator connects may be jacket covers, which include user interface controls for operating the wireless communicator; or they may be electronic devices having other functionality including inter alia cameras, media players and portable digital assistants (PDAs). For ease of exposition, these devices to which the wireless communicator connects are referred to herein generically as jackets. When the wireless communicator is connected to a jacket, the jacket enriches the capabilities of the wireless communicator, and the wireless communicator enriches the capabilities of the jacket.

Reference is now made to FIG. 1, which is an illustration of a wireless communicator **100** being inserted into a jacket **200**, in accordance with an embodiment of the present invention.

Reference is now made to FIG. 2, which is an illustration of wireless communicator **100**, in accordance with an embodiment of the present invention.

Reference is now made to FIG. 3, which is an illustration of jacket **200**, in accordance with an embodiment of the present invention. Jacket **200** shown in FIG. 3 includes a user interface for an audio/video player. Specifically, jacket **200** includes a microphone **271** (shown in FIG. 6), an earpiece **273**, speakers **275**, a keypad **280** and a display **285**.

It will be appreciated by those skilled in the art that the components of jacket **200** in FIG. 3 are illustrative of one jacket design, and that the present invention applies to a wide variety of jacket designs. It will similarly be appreciated that the present invention applies to a wide variety of types of wireless communicators, including inter alia 2.5G communicators, 3G communicators and CDMA communicators. In this regard reference is now made to FIG. 4, which is an illustration of a plurality of wireless communicators **100a-100c** and a plurality of jackets **200a-200h**, whereby each wireless communicator **100a-100c** may be attached to any of the jackets **200a-200h** so as to operate in combination therewith, in accordance with an embodiment of the present invention.

Reference is now made to FIG. 5, which is a simplified block diagram of wireless communicator **100**, in accordance with an embodiment of the present invention. Wireless communicator **100** includes eight primary components, as follows: a global positioning system (GPS) **101**, a real time clock (RTC) **102**, a connection controller **110**, a memory storage **115**, a modem **120** for sending and receiving data and voice communications, a power management subsystem **125**, a power amplifier **135** and a user interface **170**.

Modem **120** includes a log manager **121**, which writes and maintains a history log **116** in storage **115**, recording a history of jackets to which wireless communicator **100** is attached and detached. Each record in history log **116** includes entries for (i) jacket, (ii) location and (iii) time, indicating where and when wireless communicator **100** was attached to and detached from each jacket **200**. Jackets **200** are specified in

history log **116** by a jacket UID. Location is specified in history log **116** by using GPS **101**. Time is specified in history log **116** as a date & time according to RTC **102**. Since history log **116** is maintained by wireless communicator **100**, there is no need for transmitters and power sources in the jackets.

Further in accordance with an embodiment of the present invention, log manager **121** updates history log **116** upon occurrence of log trigger events. Such log trigger events include inter alia one or more of the following events:

- Attachment of wireless communicator **100** to a jacket **200**;
- Detachment of wireless communicator **100** from a jacket **200**;
- Powering on of wireless communicator **100**;
- Powering off of wireless communicator **100**;
- Dialing a phone number;
- Sending SMS/MMS messages;
- Browsing specified websites;
- Playing audio/video files;
- Arriving at a location of interest;
- Departing from a location of interest; and
- Passing of a designated time period.

Connection controller **110** executes programmed instructions that control the data flow between wireless communicator **100** and jacket **200**. Modem **120** controls the wireless communication functionality of wireless communicator **100**. Power management subsystem **125** includes charging circuitry for charging a battery **145**. Power amplifier **135** includes a radio frequency (RF) interface **136**, and is connected to an antenna **140**. User interface **170** includes a microphone **171** and an earpiece **173**. User interface **170** also includes an optional speaker **175**, an optional vibrator **177**, an optional keyboard **180** and an optional display **185**. It will be appreciated by those skilled in the art that user interface **170** may include additional components.

Wireless communicator **100** includes an optional audio/video subsystem **130**, which includes inter alia a voice, audio and video interface.

Wireless communicator **100** includes a connector **150**, which itself includes a jacket connector **160** and an optional USB connector **155**. Jacket connector **160** is used for attaching wireless communicator **100** to jacket **200**. Wireless communicator **100** optionally includes a subscriber identification module (SIM) **190**.

Wireless communicator **100** operates in standalone mode or in conjunction with jackets, such as jacket **200** shown in FIG. 3, when it is connected to the jackets via connector **160**.

In accordance with an embodiment of the present invention, the interface between connection controller **110** and storage **115**, and the interface between connection controller **110** and modem **120** are SD interfaces. The interface between connection controller **110** and jacket connector **160** is a customized connector interface.

Reference is now made to FIG. 6, which is simplified block diagram of jacket **200**, in accordance with an embodiment of the present invention. Jacket **200** includes a connection controller **210** and a wireless communicator connector **260**, for attaching wireless communicator **100** to jacket **200** via the wireless communicator's connector **160**. Jacket **200** includes an optional auxiliary processor **205**, an optional storage **215**, an optional power management subsystem **225**, an optional battery **245**, and an optional SIM **290**.

Jacket **200** comes with a user interface **270** including an optional microphone **271**, an optional earpiece **273**, an optional mono speaker or optional stereo speakers **275**, an optional vibrator **277**, an optional keyboard **280** and an

5

optional display **285**. It will be appreciated by those skilled in the art that user interface **270** may include additional components.

In accordance with an embodiment of the present invention, the interface between connection controller **210** and storage **215** is an SD interface. The interface between connection controller **210** and connector **260** is a customized connector interface.

Reference is now made to FIG. 7, which is a simplified flowchart of a method for locating a misplaced jacket using a history log stored in the wireless communicator, in accordance with an embodiment of the present invention. At step **710** an owner attaches his wireless communicator **100** to one of a plurality of his jackets **200**, such as one of the jackets shown in FIG. 4. At step **720** the owner, in using the jacket to which wireless communicator is attached, activates a log trigger event. At step **730** the owner detaches his wireless communicator **100**. Processing then returns to step **710** where the owner attaches his wireless communicator **100** to the same or to a different jacket **200**.

At each event **710**, **720** and **730**, log manager **121** updates history log **116** with an entry recording the specific jacket **200** being used at the event, the location of the event, and the date & time of the event, as indicated at step **740**.

At step **750** the owner reviews the history log in his wireless communicator **100** to locate the whereabouts of one or more jackets that he misplaced after detaching wireless communicator **100** therefrom.

An example usage scenario is that of a user who uses his wireless communicator **100** in his car, by attaching it a jacket, such as jacket **200a** of FIG. 4, which is an audio deck for a car. If the user forgets where he parked his car, he can review the history log of his wireless communicator **100** to find the last location of audio deck jacket **200a**. Moreover, in an embodiment of the present invention GPS **101** directs the owner to the location of his parked car as recorded in the history log.

In reading the above description, persons skilled in the art will realize that there are many apparent variations that can be applied to the methods and systems described. Thus it may be appreciated that GPS **101** is not required in some embodiments of the present invention. Instead, wireless communicator **100** determines its position based on connections to other devices in its vicinity using inter alia Near Field Communication (NFC), Radio Frequency Identification (RFID), Bluetooth, infra-red (IR) and WiFi connections. E.g., a user may connect wireless communicator **100** and jacket **200** to a WiFi hot spot in a coffee shop, and the location of the coffee shop is recorded in history log **116**.

In the foregoing specification, the invention has been described with reference to specific exemplary embodiments thereof. It will, however, be evident that various modifications and changes may be made to the specific exemplary embodiments without departing from the broader spirit and scope of the invention as set forth in the appended claims. Accordingly, the specification and drawings are to be regarded in an illustrative rather than a restrictive sense.

What is claimed is:

1. A locator system for electronic devices comprising:
  - at least one jacket for a modular wireless communicator, each jacket having an identifier; and
  - a modular wireless communicator that attaches to each one of said at least one jacket, comprising:
    - a positioning system for identifying a location of the modular wireless communicator;
    - a log manager, coupled with said positioning system, for recording a plurality of entries in a log, each entry comprising the jacket identifier for a jacket currently

6

attached to the modular wireless communicator, and a current location as identified by said positioning system; and

a controller coupled with said log manager for notifying said log manager of occurrence of a log trigger event, wherein said log manager records a new entry in the log when it receives a notification of a log trigger event from said controller, wherein the log trigger event includes a designated action performed by a jacket to which said modular wireless communicator is attached, from among the group consisting of sending an SMS or an MMS message, browsing a designated web site, and playing an audio or a video file, whereby the log trigger events enable determination of a location where a jacket was last actively used with said modular wireless communicator.

2. The locator system of claim 1 wherein said modular wireless communicator further comprises a log reader, for viewing the plurality of entries recorded in the log.

3. The locator system of claim 1 wherein said positioning system generates navigable directions to reach a designated one of the locations recorded in the log.

4. The locator system of claim 1 wherein said positioning system is a global positioning system (GPS).

5. The locator system of claim 1 wherein said positioning system is a cellular based positioning system.

6. The locator system of claim 1 wherein said positioning system identifies the location of said wireless communicator based on a connection to a device in its vicinity.

7. The locator system of claim 6 wherein said positioning system identifies the location of said modular wireless communicator based on a near field communication (NFC) connection.

8. The locator system of claim 6 wherein said positioning system identifies the location of said modular wireless communicator based on a radio frequency identification (RFID) connection.

9. The locator system of claim 6 wherein said positioning system identifies the location of said modular wireless communicator based on a BLUETOOTH® connection.

10. The locator system of claim 6 wherein said positioning system identifies the location of said modular wireless communicator based on a WiFi connection.

11. The locator system of claim 6 wherein said positioning system identifies the location of said modular wireless communicator based on an infrared (IR) connection.

12. A locator method, comprising:
 

- maintaining a log for a wireless communicator that attaches to at least one jacket, each jacket having an identifier, the log comprising a plurality of entries and each entry comprising a jacket identifier and a location;
- monitoring the wireless communicator for detection of occurrence of a log trigger event, wherein the log trigger event includes a designated action performed by a jacket to which the modular wireless communicator is attached, from among the group consisting of sending an SMS or an MMS message, browsing a designated web site, and playing an audio or a video file, whereby the log trigger events enable determination of a location where a jacket was last actively used with the wireless communicator; and
- in response to detection of occurrence of a log trigger event, adding a new entry to the log.

13. The method of claim 12 further comprising presenting a view of the log to a user.

14. The method of claim 12 further comprising generating navigable directions to reach a designated one of the locations recorded in the log.

15. The method of claim 12 further comprising identifying the location in the history log entry based on a connection of the wireless communicator to a device in its vicinity.

16. The method of claim 15 further comprising identifying the location in the history log entry based on a near field communication (NFC) connection. 5

17. The method of claim 15 further comprising identifying the location in the history log entry based on a radio frequency identification (RFID) connection.

18. The method of claim 15 further comprising identifying the location in the history log entry based on a BLUE-TOOTH® connection. 10

19. The method of claim 15 further comprising identifying the location in the history log entry based on a WiFi connection. 15

20. The method of claim 15 further comprising identifying the location in the history log entry based on an infrared (IR) connection.

\* \* \* \* \*