



US008918252B2

(12) **United States Patent**
Fröjdh et al.

(10) **Patent No.:** **US 8,918,252 B2**

(45) **Date of Patent:** ***Dec. 23, 2014**

(54) **LIGHT-BASED TOUCH CONTROLS ON A STEERING WHEEL**

(71) Applicant: **Neonode Inc.**, Santa Clara, CA (US)

(72) Inventors: **Gunnar Martin Fröjdh**, Dalarö (SE); **Simon Fellin**, Sigtuna (SE); **Thomas Eriksson**, Stockholm (SE); **John Karlsson**, Märsta (SE); **Maria Hedin**, Bromma (SE); **Richard Berglund**, Älvsjö (SE)

(73) Assignee: **Neonode Inc.**, Santa Clara, CA (US)

(*) Notice: Subject to any disclaimer, the term of this patent is extended or adjusted under 35 U.S.C. 154(b) by 0 days.

This patent is subject to a terminal disclaimer.

(21) Appl. No.: **14/312,711**

(22) Filed: **Jun. 24, 2014**

(65) **Prior Publication Data**

US 2014/0303841 A1 Oct. 9, 2014

Related U.S. Application Data

(63) Continuation of application No. 14/088,458, filed on Nov. 25, 2013, now Pat. No. 8,775,023, which is a

(Continued)

(51) **Int. Cl.**

G06F 7/00 (2006.01)

H04N 21/422 (2011.01)

G06F 3/01 (2006.01)

B60R 16/037 (2006.01)

G06F 3/03 (2006.01)

G06F 3/041 (2006.01)

G06F 3/033 (2013.01)

(52) **U.S. Cl.**

CPC **H04N 21/42201** (2013.01); **G06F 3/017** (2013.01); **G06F 3/041** (2013.01); **G06F 3/033** (2013.01); **H04M 2250/22** (2013.01); **B60R 16/037** (2013.01); **G06F 3/0304** (2013.01)

USPC **701/36**; 701/41; 701/418

(58) **Field of Classification Search**

CPC G06F 3/017; G06F 3/0304; G06F 3/033; G06F 3/041; H04M 2250/22; B60R 16/037

USPC 701/36, 41, 418
See application file for complete search history.

(56) **References Cited**

U.S. PATENT DOCUMENTS

4,243,879 A 1/1981 Carroll et al.

4,301,447 A 11/1981 Funk et al.

(Continued)

FOREIGN PATENT DOCUMENTS

EP 0330767 A1 9/1989

EP 0513694 A2 11/1992

(Continued)

OTHER PUBLICATIONS

Moeller et al., ZeroTouch: An Optical Multi-Touch and Free-Air Interaction Architecture, Proc. CHI 2012, Proceedings of the 2012 Annual Conference Extended Abstracts on Human Factors in Computing Systems, pp. 2165-2174, ACM, New York, NY, USA, May 5, 2012.

(Continued)

Primary Examiner — Gertrude Arthur Jeanglaude

(74) *Attorney, Agent, or Firm* — Soquel Group LLC

(57) **ABSTRACT**

A system for use in a vehicle, including a steering element situated opposite a driver seat in a vehicle, the steering element including a plurality of proximity sensors encased in the periphery of the steering element operable to detect hand gestures along the outer periphery of the steering element, an interactive deck housed in the vehicle, for providing at least one of radio broadcast, video broadcast, audio entertainment, video entertainment and navigational assistance in the vehicle, and a processor housed in the vehicle, coupled with the proximity sensors and the deck, operable to identify the hand gestures detected by the proximity sensors, and to control the deck in response to thus-identified hand gestures.

10 Claims, 38 Drawing Sheets

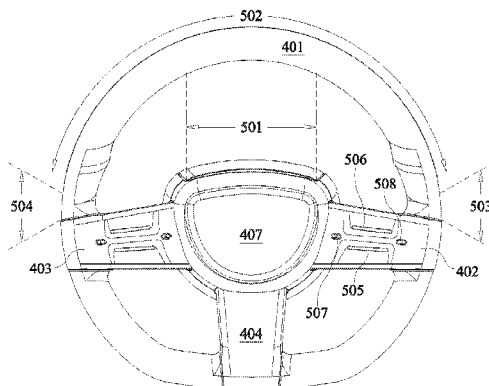

Related U.S. Application Data

continuation-in-part of application No. 13/854,074, filed on Mar. 30, 2013, now Pat. No. 8,810,551, and a continuation-in-part of application No. 13/775,269, filed on Feb. 25, 2013, and a continuation-in-part of application No. 13/424,543, filed on Mar. 20, 2012, said application No. 13/854,074 is a continuation of application No. 13/424,592, filed on Mar. 20, 2012, now Pat. No. 8,416,217, said application No. 13/775,269 is a continuation-in-part of application No. 13/732,456, filed on Jan. 2, 2013, now Pat. No. 8,643,628, said application No. 13/424,543 is a continuation-in-part of application No. PCT/US2011/029191, filed on Mar. 21, 2011, and a continuation-in-part of application No. 12/371,609, filed on Feb. 15, 2009, now Pat. No. 8,339,379, and a continuation-in-part of application No. 12/760,567, filed on Apr. 15, 2010, and a continuation-in-part of application No. 12/760,568, filed on Apr. 15, 2010.

- (60) Provisional application No. 61/730,139, filed on Nov. 27, 2012, provisional application No. 61/564,868, filed on Nov. 30, 2011, provisional application No. 61/564,164, filed on Nov. 28, 2011, provisional application No. 61/379,012, filed on Sep. 1, 2010, provisional application No. 61/380,600, filed on Sep. 7, 2010, provisional application No. 61/410,930, filed on Nov. 7, 2010, provisional application No. 61/169,779, filed on Apr. 16, 2009.

(56)

References Cited

U.S. PATENT DOCUMENTS

4,518,249 A 5/1985 Murata et al.
 4,550,250 A 10/1985 Mueller et al.
 4,703,316 A 10/1987 Sherbeck
 4,710,760 A 12/1987 Kasday
 4,782,328 A 11/1988 Denlinger
 4,790,028 A 12/1988 Ramage
 4,847,606 A 7/1989 Beiswenger
 4,880,969 A 11/1989 Lawrie
 4,928,094 A 5/1990 Smith
 5,003,505 A 3/1991 McClelland
 5,016,008 A 5/1991 Gruaz et al.
 5,036,187 A 7/1991 Yoshida et al.
 5,053,758 A 10/1991 Cornett et al.
 5,103,085 A 4/1992 Zimmerman
 5,119,079 A 6/1992 Hube et al.
 5,162,783 A 11/1992 Moreno
 5,179,369 A 1/1993 Person et al.
 5,194,863 A 3/1993 Barker et al.
 5,220,409 A 6/1993 Bures
 5,283,558 A 2/1994 Chan
 5,406,307 A 4/1995 Hirayama et al.
 5,414,413 A 5/1995 Tamaru et al.
 5,422,494 A 6/1995 West et al.
 5,463,725 A 10/1995 Henckel et al.
 5,559,727 A 9/1996 Deley et al.
 5,577,733 A 11/1996 Downing
 5,579,035 A 11/1996 Beiswenger
 5,603,053 A 2/1997 Gough et al.
 5,612,719 A 3/1997 Beernink et al.
 5,618,232 A 4/1997 Martin
 5,729,250 A 3/1998 Bishop et al.
 5,748,185 A 5/1998 Stephan et al.
 5,785,439 A 7/1998 Bowen
 5,825,352 A 10/1998 Bisset et al.
 5,838,308 A 11/1998 Knapp et al.
 5,880,743 A 3/1999 Moran et al.
 5,886,697 A 3/1999 Naughton et al.
 5,889,236 A 3/1999 Gillespie et al.
 5,900,875 A 5/1999 Haitani et al.

5,914,709 A 6/1999 Graham et al.
 5,936,615 A 8/1999 Waters
 5,943,043 A 8/1999 Furuhashi et al.
 5,943,044 A 8/1999 Martinelli et al.
 5,956,030 A 9/1999 Conrad et al.
 5,988,645 A 11/1999 Downing
 6,010,061 A 1/2000 Howell
 6,023,265 A 2/2000 Lee
 6,031,989 A 2/2000 Cordell
 6,052,279 A 4/2000 Friend et al.
 6,073,036 A 6/2000 Heikkinen et al.
 6,085,204 A 7/2000 Chijiwa et al.
 6,091,405 A 7/2000 Lowe et al.
 6,114,949 A * 9/2000 Schmitz et al. 340/425.5
 6,246,395 B1 6/2001 Goyins et al.
 6,259,436 B1 7/2001 Moon et al.
 6,292,179 B1 9/2001 Lee
 6,323,846 B1 11/2001 Westerman et al.
 6,340,979 B1 1/2002 Beaton et al.
 6,346,935 B1 2/2002 Nakajima et al.
 6,356,287 B1 3/2002 Ruberry et al.
 6,359,632 B1 3/2002 Easty et al.
 6,362,468 B1 3/2002 Murakami et al.
 6,411,283 B1 6/2002 Murphy
 6,421,042 B1 7/2002 Omura et al.
 6,429,857 B1 8/2002 Masters et al.
 6,456,952 B1 9/2002 Nathan
 6,529,920 B1 3/2003 Arons et al.
 6,542,191 B1 4/2003 Yonezawa
 6,549,217 B1 4/2003 De Greef et al.
 6,570,557 B1 5/2003 Westerman et al.
 6,597,345 B2 7/2003 Hirshberg
 6,628,268 B1 9/2003 Harada et al.
 6,639,584 B1 10/2003 Li
 6,646,633 B1 11/2003 Nicolas
 6,677,932 B1 1/2004 Westerman
 6,690,365 B2 2/2004 Hinckley et al.
 6,690,387 B2 2/2004 Zimmerman et al.
 6,707,449 B2 3/2004 Hinckley et al.
 6,727,917 B1 4/2004 Chew et al.
 6,734,883 B1 5/2004 Wynn et al.
 6,757,002 B1 6/2004 Oross et al.
 6,788,292 B1 9/2004 Nako et al.
 6,803,906 B1 10/2004 Morrison et al.
 6,833,827 B2 12/2004 Lui et al.
 6,836,367 B2 12/2004 Seino et al.
 6,857,746 B2 2/2005 Dyer
 6,864,882 B2 3/2005 Newton
 6,874,683 B2 4/2005 Keronen et al.
 6,888,536 B2 5/2005 Westerman et al.
 6,944,557 B2 9/2005 Hama et al.
 6,947,032 B2 9/2005 Morrison et al.
 6,954,197 B2 10/2005 Morrison et al.
 6,958,749 B1 10/2005 Matsushita et al.
 6,972,401 B2 12/2005 Akitt et al.
 6,988,246 B2 1/2006 Kopitzke et al.
 6,992,660 B2 1/2006 Kawano et al.
 7,006,077 B1 2/2006 Uusimaki
 7,007,239 B1 2/2006 Hawkins et al.
 7,030,861 B1 4/2006 Westerman et al.
 7,046,232 B2 5/2006 Inagaki et al.
 7,133,032 B2 11/2006 Cok
 7,155,683 B1 12/2006 Williams
 7,159,763 B2 1/2007 Yap et al.
 7,176,905 B2 2/2007 Baharav et al.
 7,184,030 B2 2/2007 McCharles et al.
 7,221,462 B2 5/2007 Cavallucci
 7,225,408 B2 5/2007 O'Rourke
 7,232,986 B2 6/2007 Worthington et al.
 7,254,775 B2 8/2007 Geaghan et al.
 7,265,748 B2 9/2007 Ryyanen
 7,283,845 B2 10/2007 De Bast
 7,286,063 B2 10/2007 Gauthey et al.
 RE40,153 E 3/2008 Westerman et al.
 7,339,580 B2 3/2008 Westerman et al.
 7,352,940 B2 4/2008 Charters et al.
 7,355,594 B2 4/2008 Barkan
 7,369,724 B2 5/2008 Deane
 7,372,456 B2 5/2008 McLintock

(56)

References Cited

FOREIGN PATENT DOCUMENTS

U.S. PATENT DOCUMENTS

7,429,706 B2 9/2008 Ho
 7,435,940 B2 10/2008 Eliasson et al.
 7,441,196 B2 10/2008 Gottfurcht et al.
 7,441,800 B2 10/2008 Weber et al.
 7,442,914 B2 10/2008 Eliasson et al.
 7,464,110 B2 12/2008 Pyhalammii et al.
 7,465,914 B2 12/2008 Eliasson et al.
 7,469,381 B2 12/2008 Ordning
 7,479,949 B2 1/2009 Jobs et al.
 7,518,738 B2 4/2009 Cavallucci et al.
 7,633,300 B2 12/2009 Keroe et al.
 7,663,607 B2 2/2010 Hotelling et al.
 7,705,835 B2 4/2010 Eikman
 7,742,290 B1 6/2010 Kaya
 7,782,296 B2 8/2010 Kong et al.
 7,812,828 B2 10/2010 Westerman et al.
 7,855,716 B2 12/2010 McCreary et al.
 7,880,724 B2 2/2011 Nguyen et al.
 7,880,732 B2 2/2011 Goertz
 8,022,941 B2 9/2011 Smoot
 8,026,798 B2 9/2011 Makinen et al.
 8,068,101 B2 11/2011 Goertz
 8,095,879 B2 1/2012 Goertz
 8,120,625 B2 2/2012 Hinckley
 8,193,498 B2 6/2012 Cavallucci et al.
 8,289,299 B2 10/2012 Newton
 8,775,023 B2 * 7/2014 Frojdh et al. 701/36
 2002/0152010 A1 10/2002 Colmenarez et al.
 2002/0158453 A1 10/2002 Levine
 2004/0199309 A1 10/2004 Hayashi et al.
 2005/0021190 A1 1/2005 Worrell et al.
 2005/0052426 A1 3/2005 Hagermoser et al.
 2006/0047386 A1 3/2006 Kanevsky et al.
 2009/0139778 A1 6/2009 Butler et al.
 2009/0166098 A1 7/2009 Sunder
 2009/0278915 A1 11/2009 Kramer et al.
 2011/0050589 A1 3/2011 Yan et al.
 2012/0109455 A1 5/2012 Newman et al.
 2012/0179328 A1 7/2012 Goldman-Shenhar
 2012/0283894 A1 11/2012 Naboulsi
 2013/0024071 A1 1/2013 Sivertsen
 2013/0063336 A1 * 3/2013 Sugimoto et al. 345/156
 2013/0204457 A1 8/2013 King et al.

EP 0601651 A1 6/1994
 EP 0618528 A1 10/1994
 EP 0703525 A1 3/1996
 EP 1059603 A2 12/2000
 GB 2423808 9/2006
 JP 03-216719 A1 9/1991
 JP 5173699 A 12/1991
 JP 11-232024 A 8/1999
 WO 8600446 A1 1/1986
 WO 8600447 A1 1/1986
 WO 9615464 A1 5/1996
 WO 0102949 A1 1/2001
 WO 0140922 A2 6/2001
 WO 02095668 A1 11/2002
 WO 03038592 A1 5/2003
 WO 03083767 A2 10/2003
 WO 2005026938 A2 3/2005
 WO 2008147266 A1 12/2008
 WO 2009008786 A1 1/2009
 WO 2010093570 A1 8/2010
 WO 2010121031 A1 10/2010
 WO 2011119483 A1 9/2011

OTHER PUBLICATIONS

Moeller et al., ZeroTouch: A Zero-Thickness Optical Multi-Touch Force Field, CHI EA '11, Proceedings of the 2011 Annual Conference Extended Abstracts on Human Factors in Computing Systems, pp. 1165-1170, ACM, New York, NY, USA, May 7, 2011.
 Moeller et al., IntangibleCanvas: Free-Air Finger Painting on a Projected Canvas, CHI EA '11, Proceedings of the 2011 Annual Conference Extended Abstracts on Human Factors in Computing Systems, pp. 1615-1620, ACM, New York, NY, USA, May 7, 2011.
 Moeller et al., Scanning FTIR: Unobtrusive Optoelectronic Multi-Touch Sensing through Waveguide Transmissivity Imaging, TEI '10, Proceedings of the Fourth International Conference on Tangible, Embedded, and Embodied Interaction, pp. 73-76, ACM, New York, NY, USA, Jan. 25, 2010.
 Myers et al., Two-Handed Input using a PDA and a Mouse, CHI '2000, CHI Letters, vol. 2, Issue 1, pp. 41-48, ACM, New York, NY, USA, 2000.
 Myers, Using Handhelds and PCs Together, Communications of the ACM, vol. 44, No. 11, pp. 34-41, ACM, New York, NY, USA, Nov. 2001.
 Myers, Mobile Devices for Control, Mobile HCI 2002, LNCS 2411, pp. 1-8, Springer-Verlag Berlin, Heidelberg, 2002.

* cited by examiner

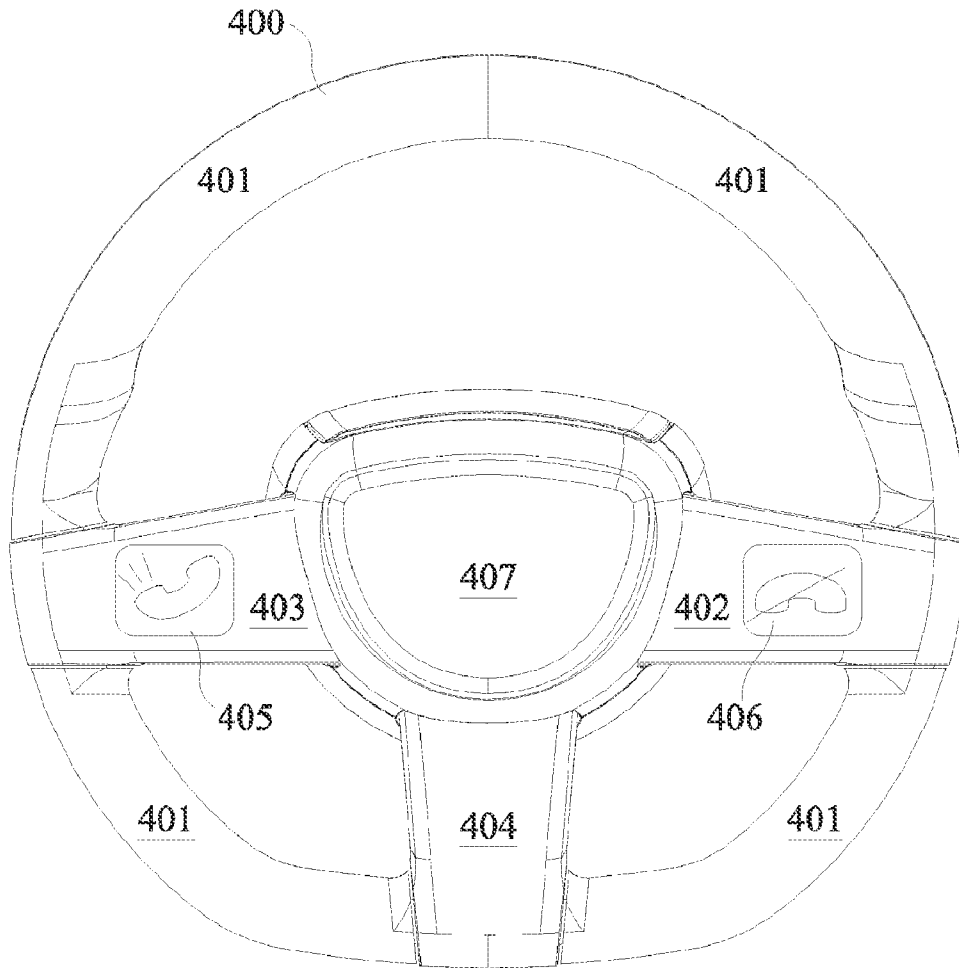

FIG. 1
(PRIOR ART)

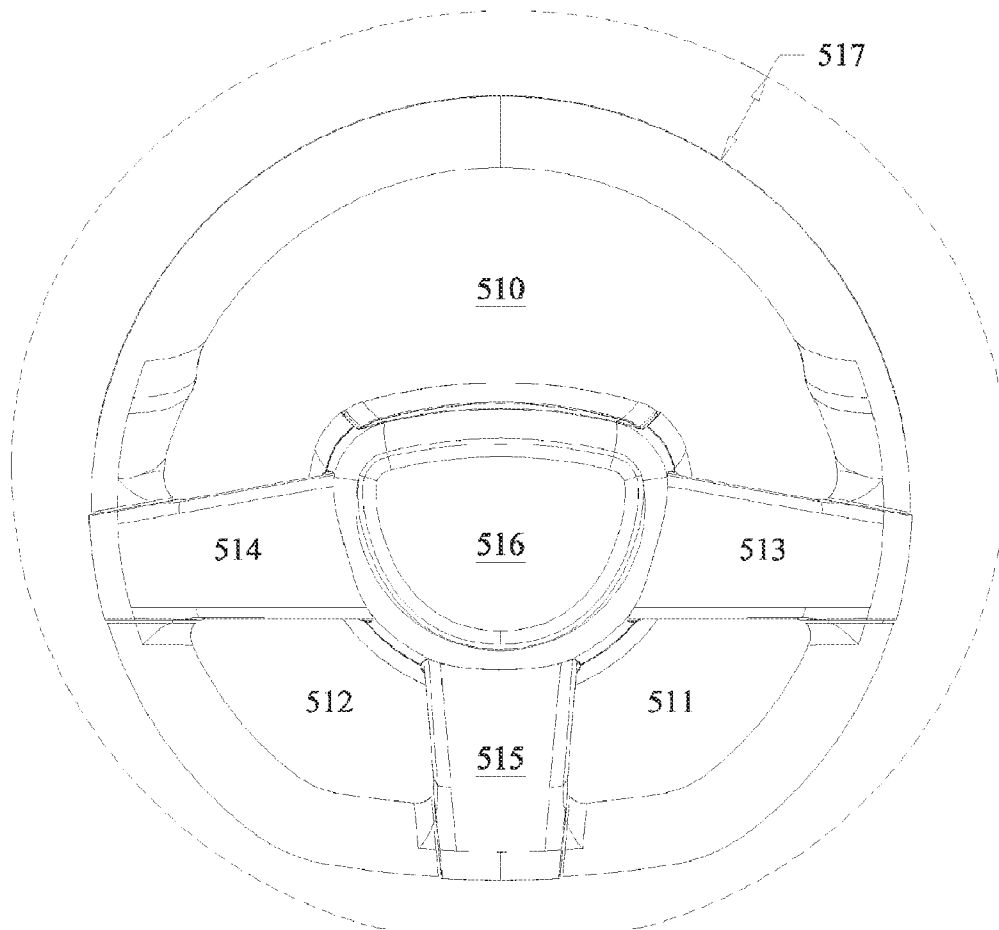

FIG. 3

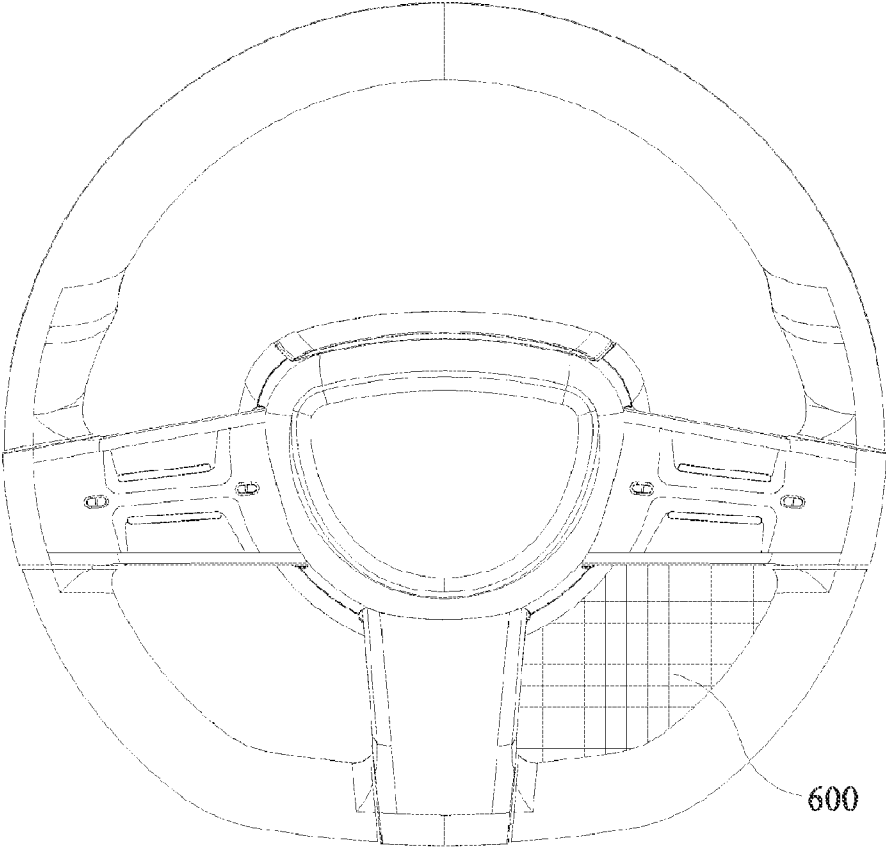

FIG. 4

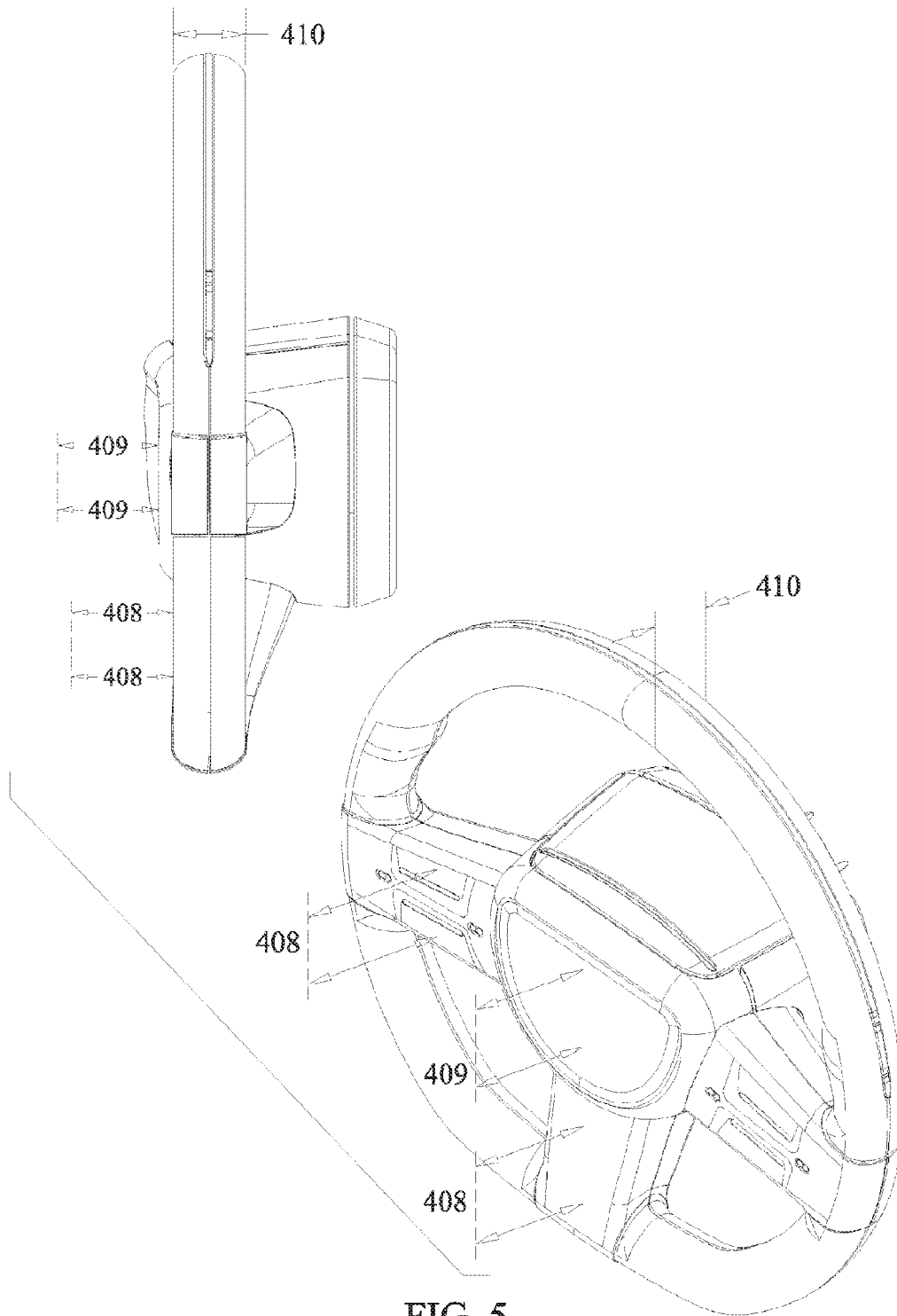

FIG. 5

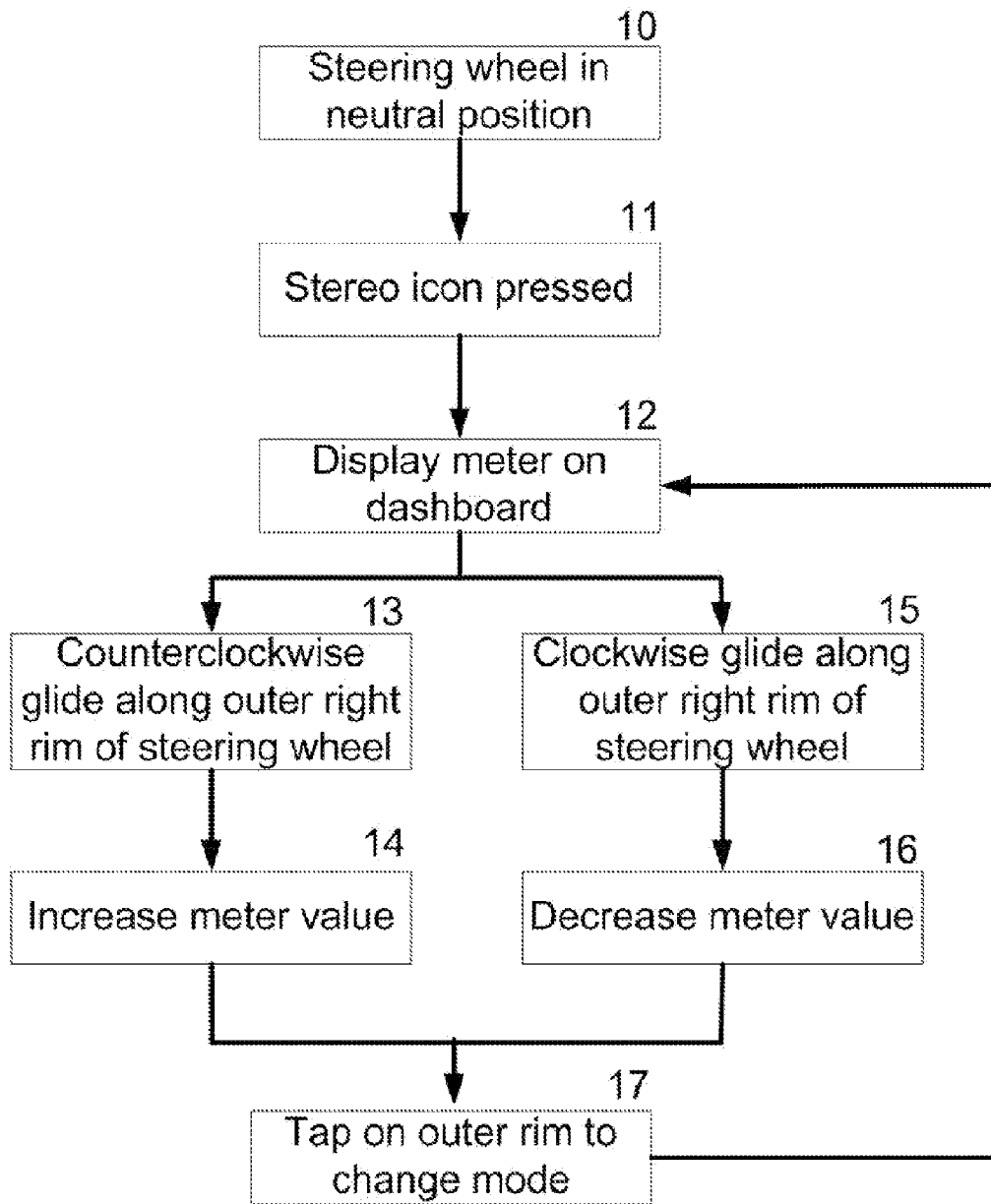

FIG. 6

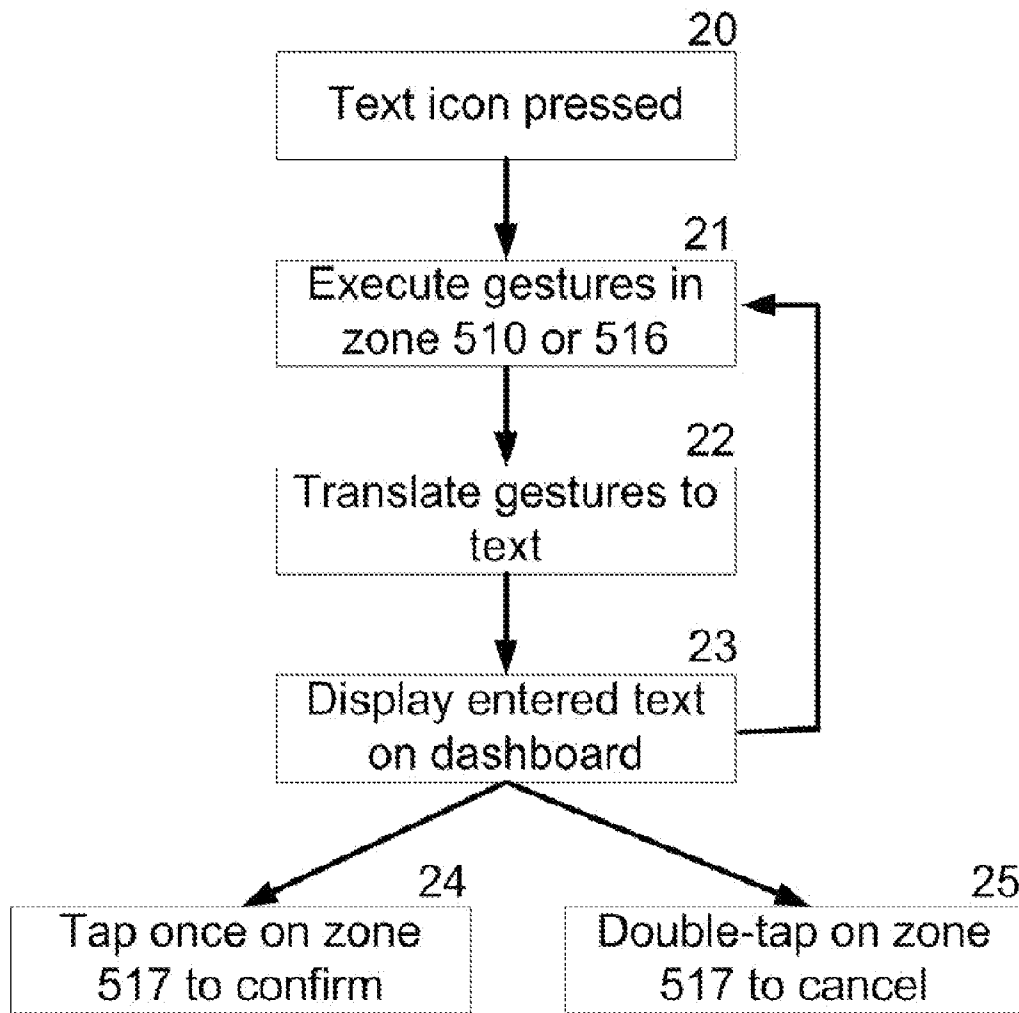

FIG. 7

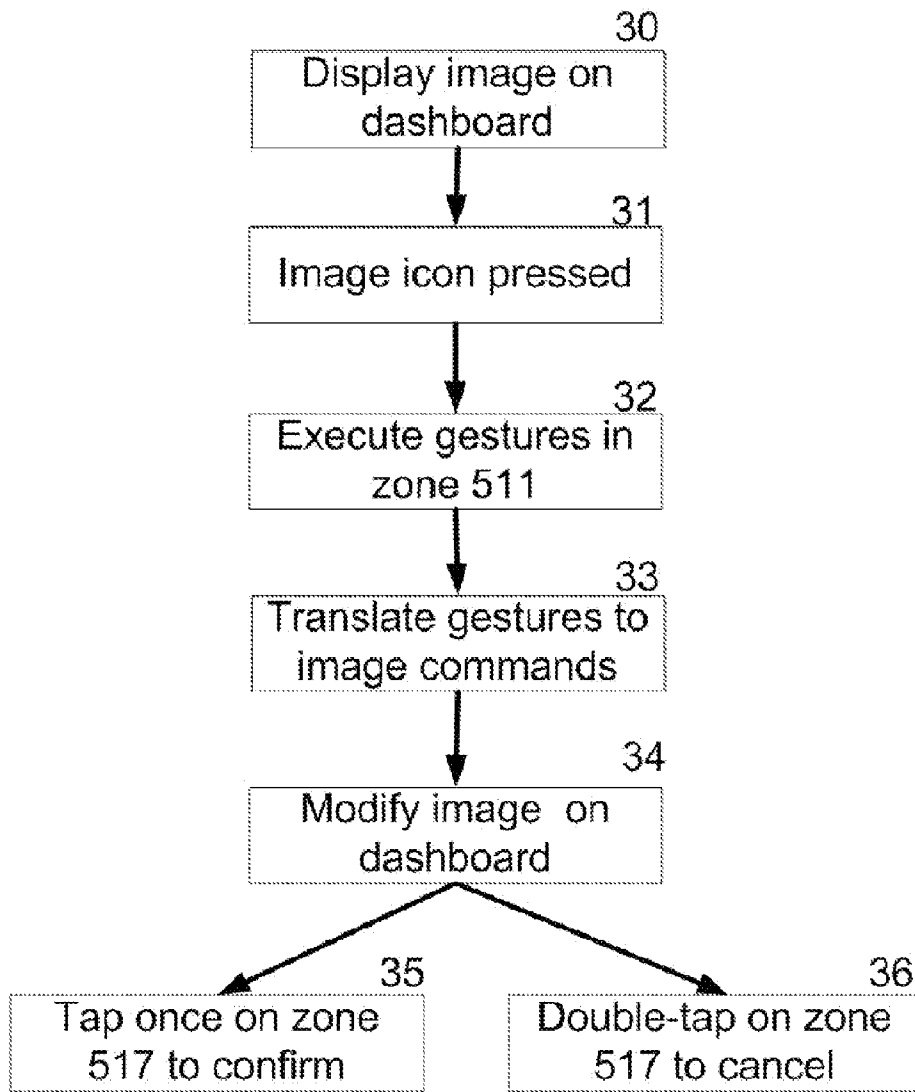

FIG. 8

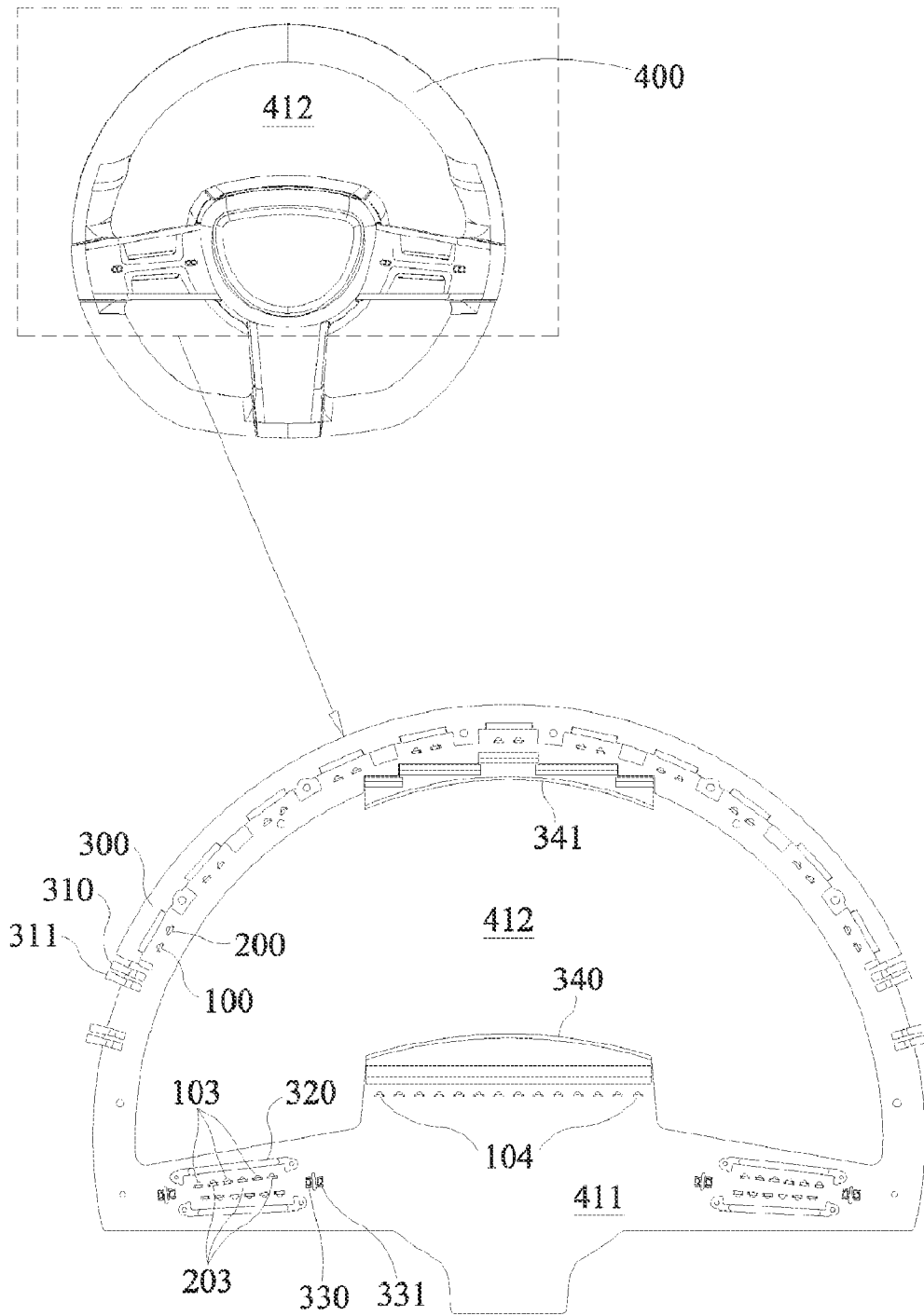

FIG. 9

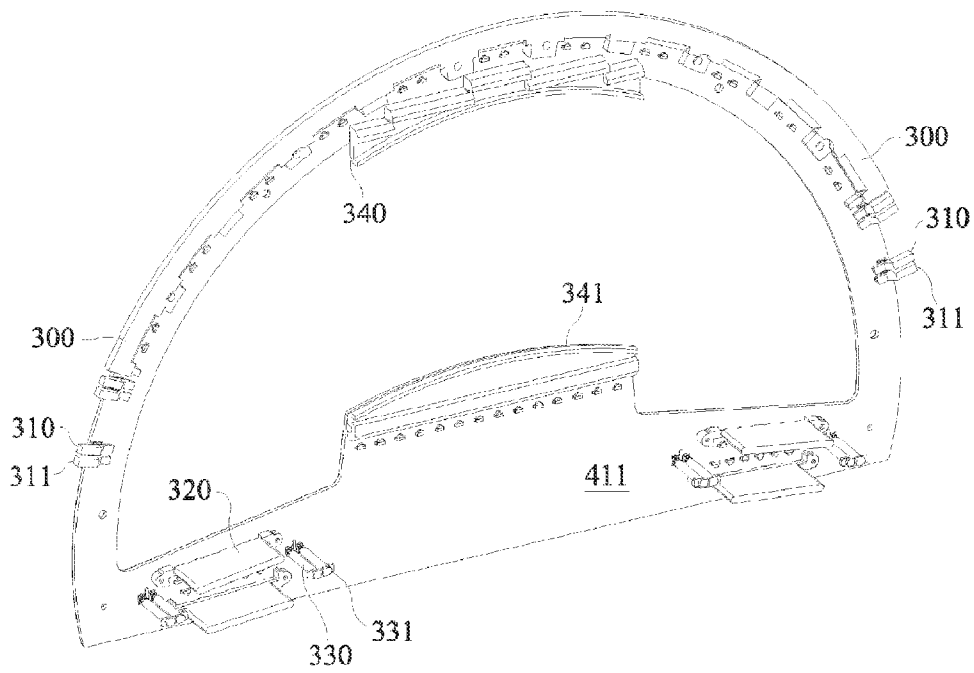

FIG. 10

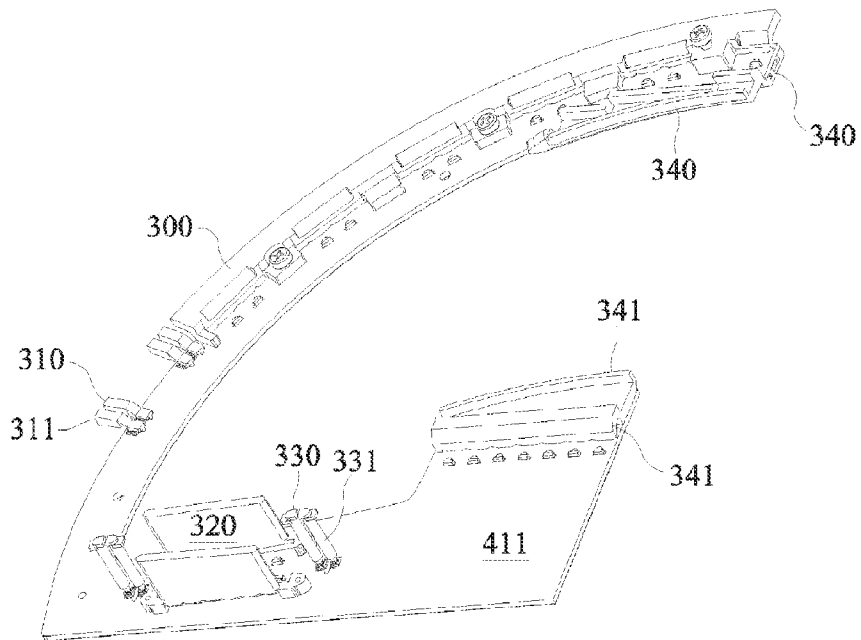

FIG. 11

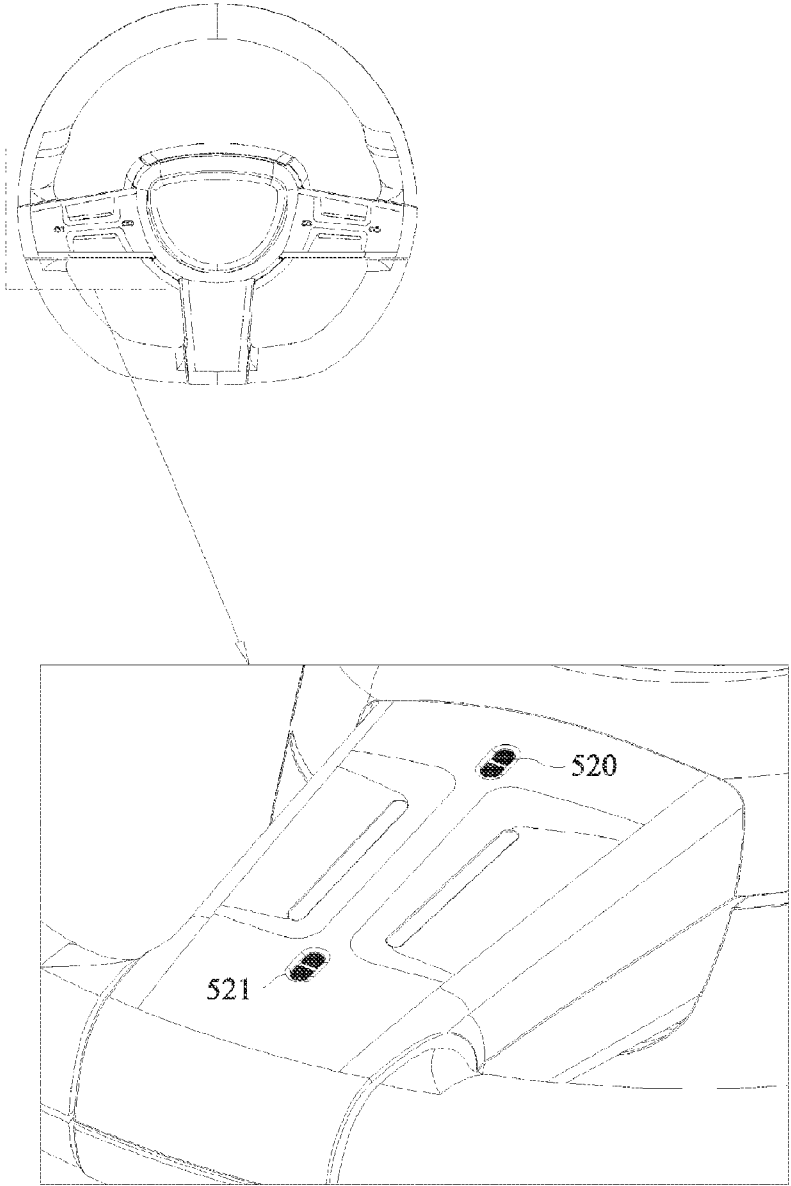

FIG. 12

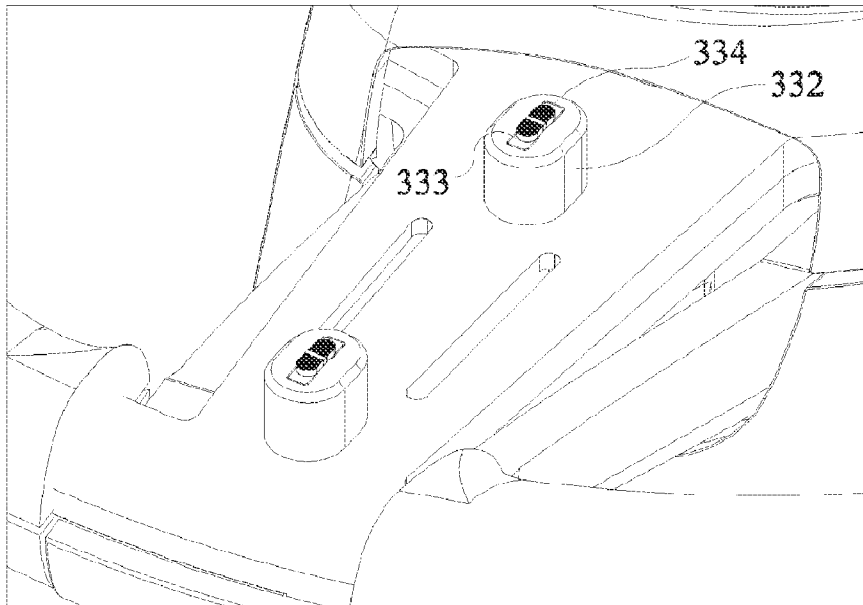

FIG. 13

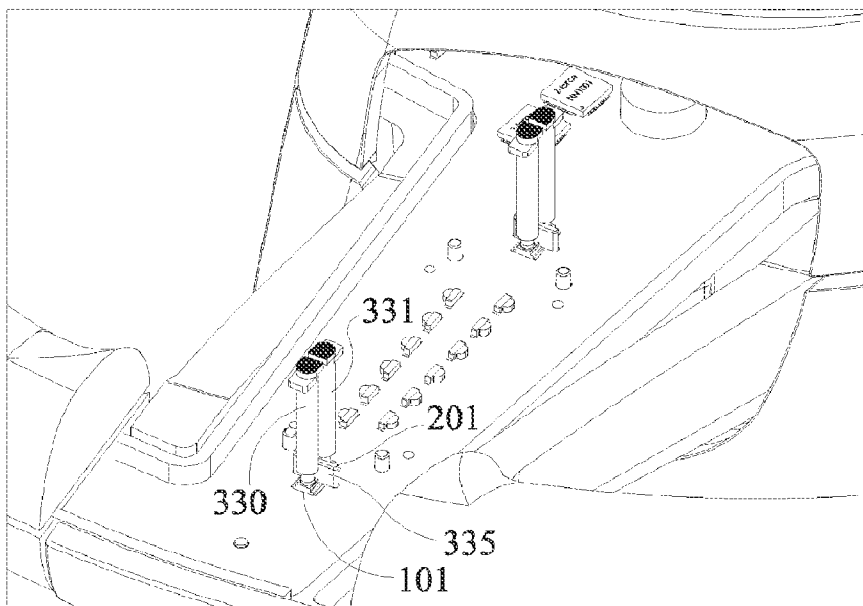

FIG. 14

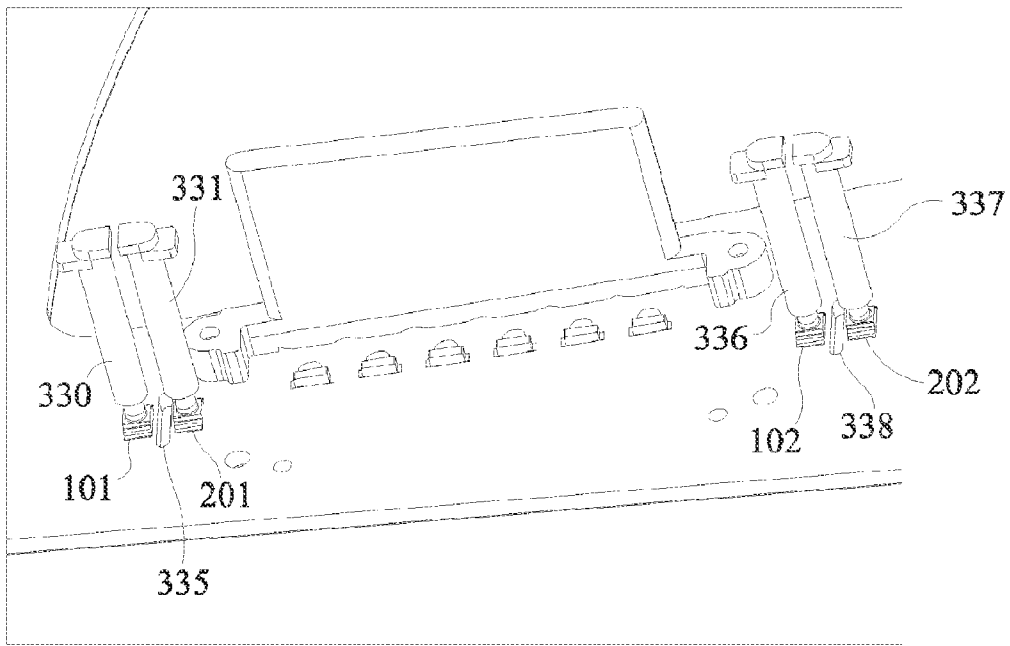

FIG. 15

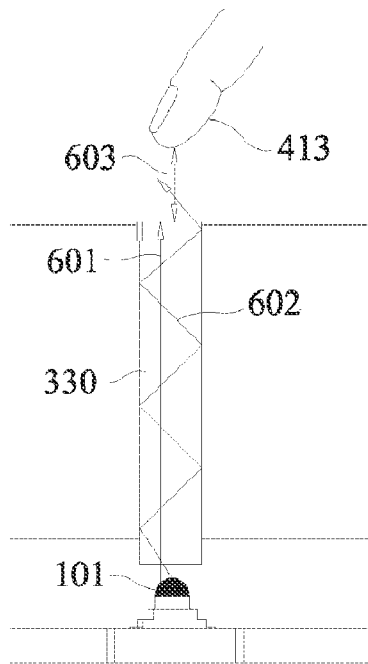

FIG. 16

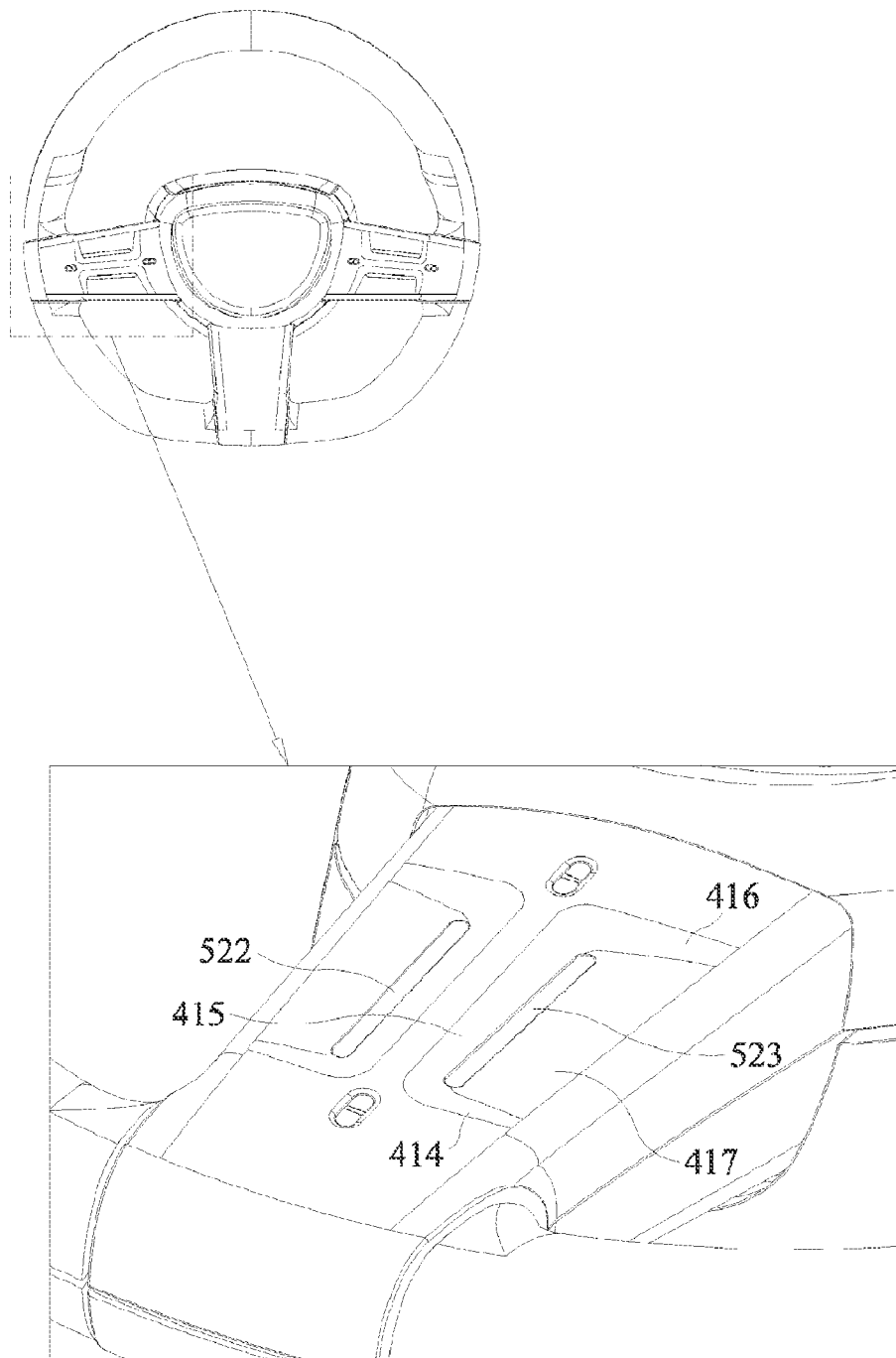

FIG. 17

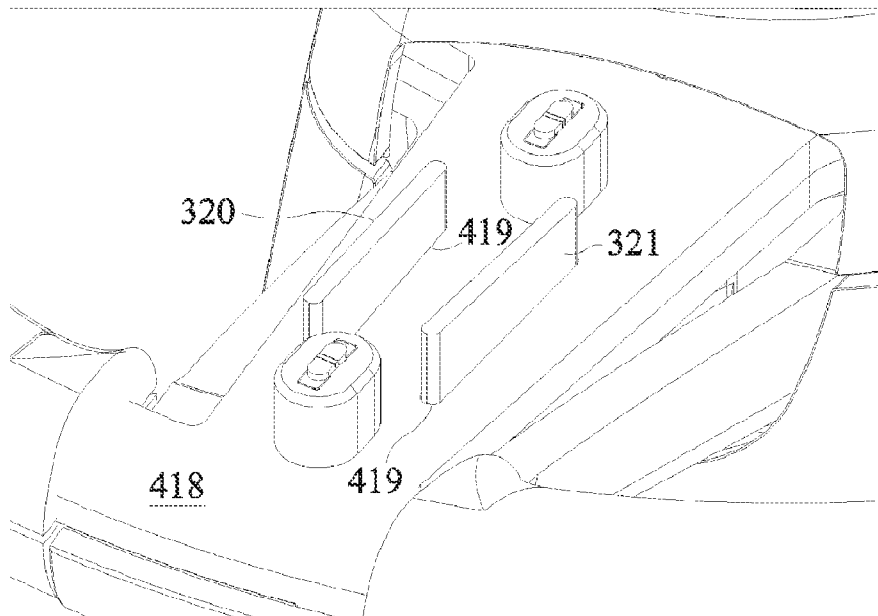

FIG. 18

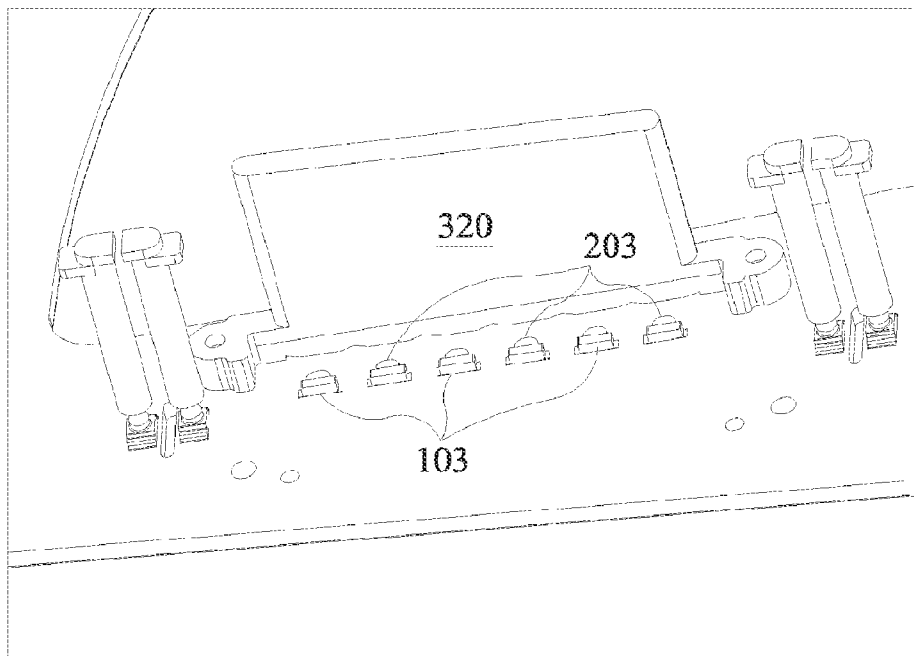

FIG. 19

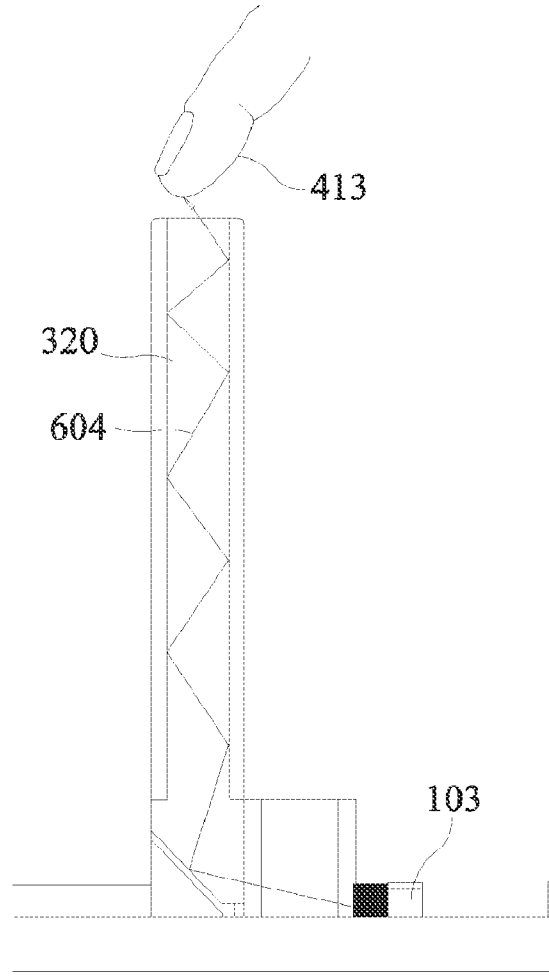

FIG. 20

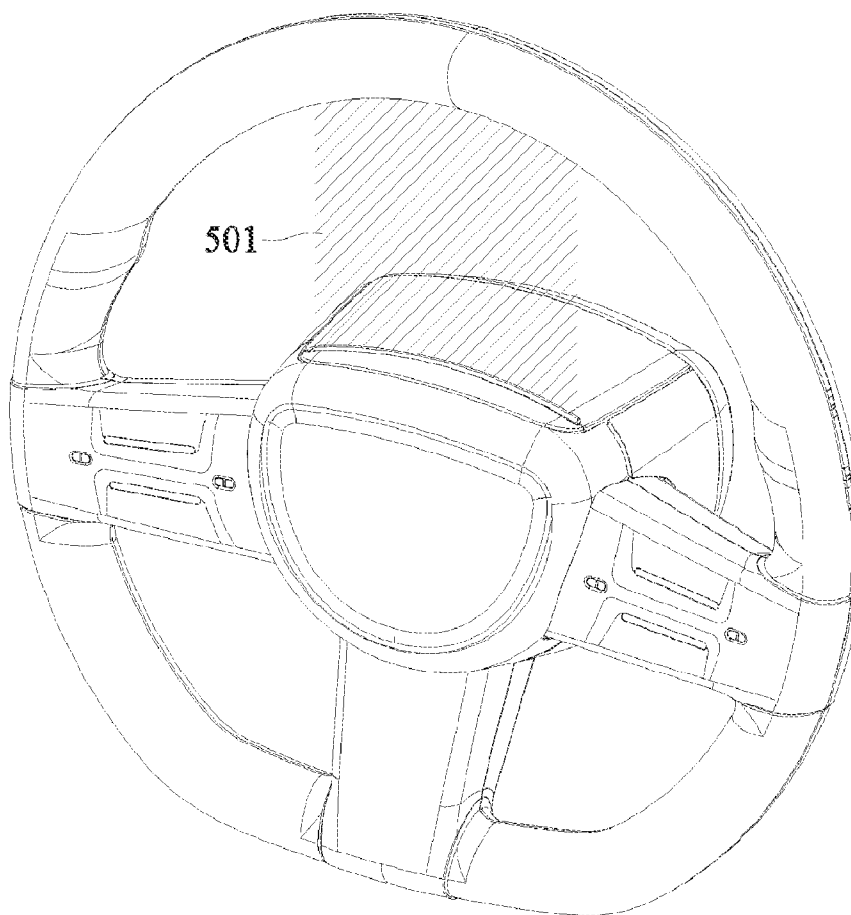

FIG. 21

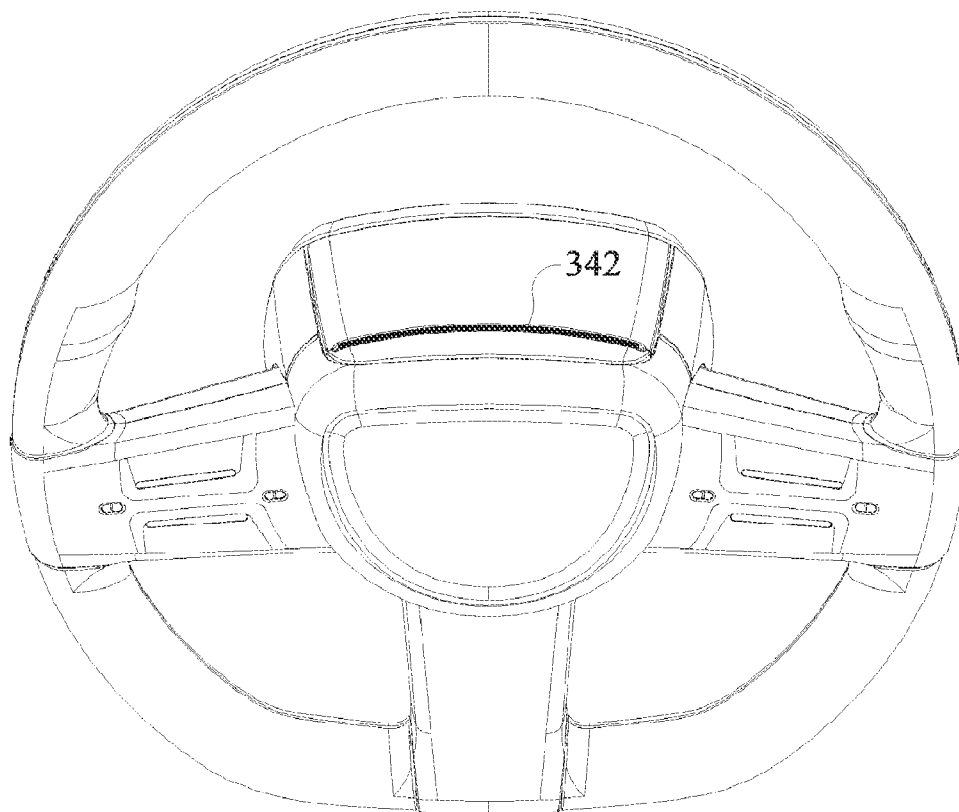

FIG. 22

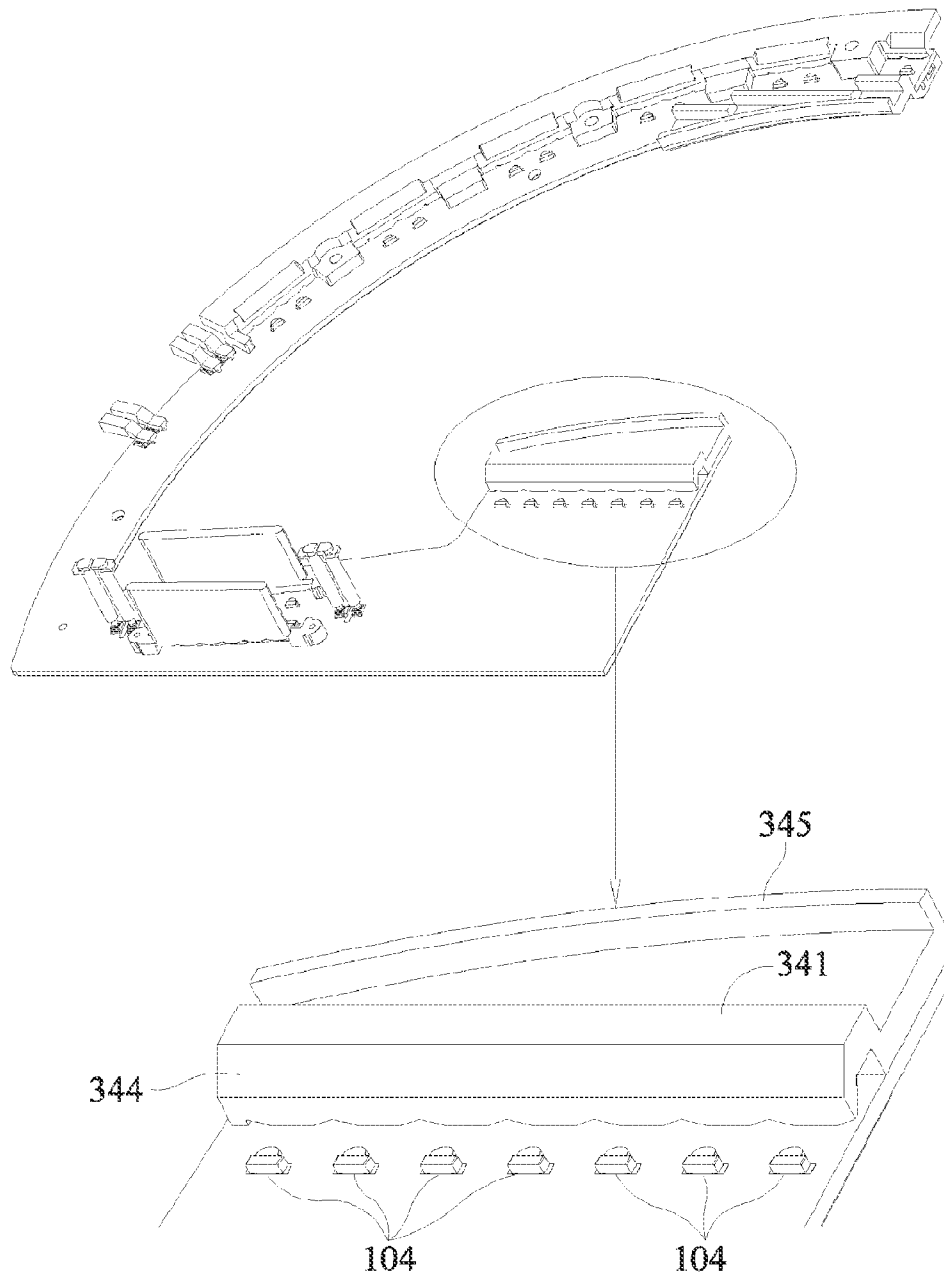

FIG. 23

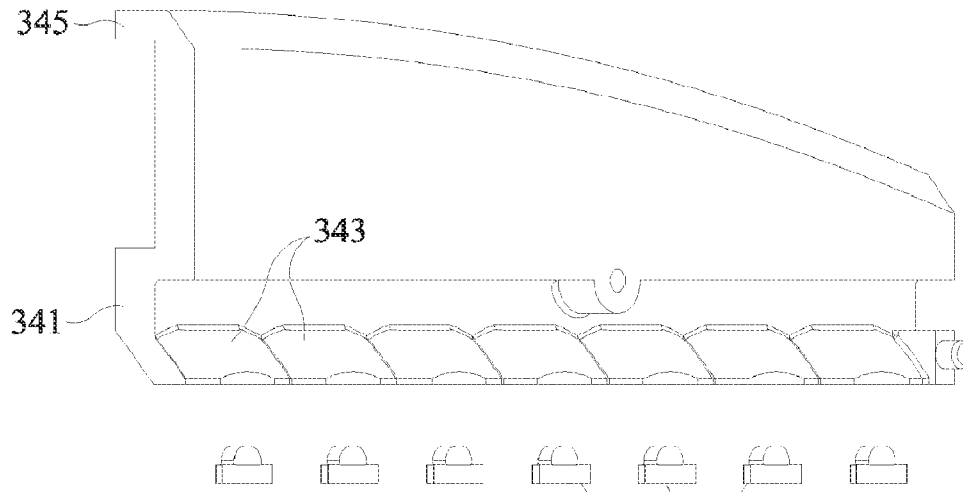

FIG. 24 104

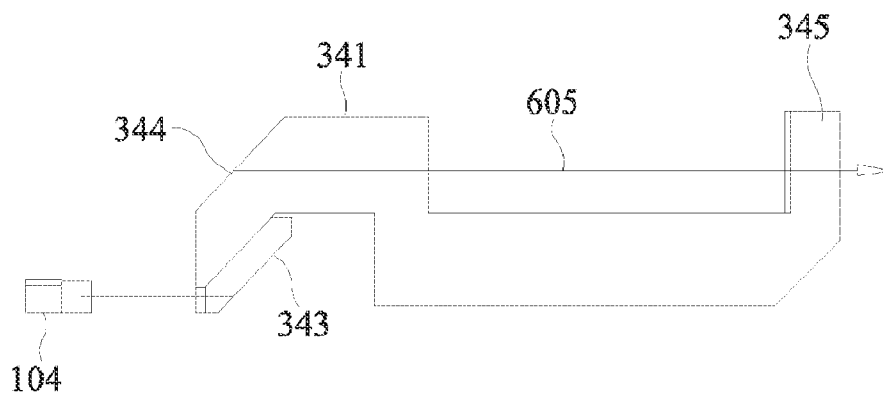

FIG. 25

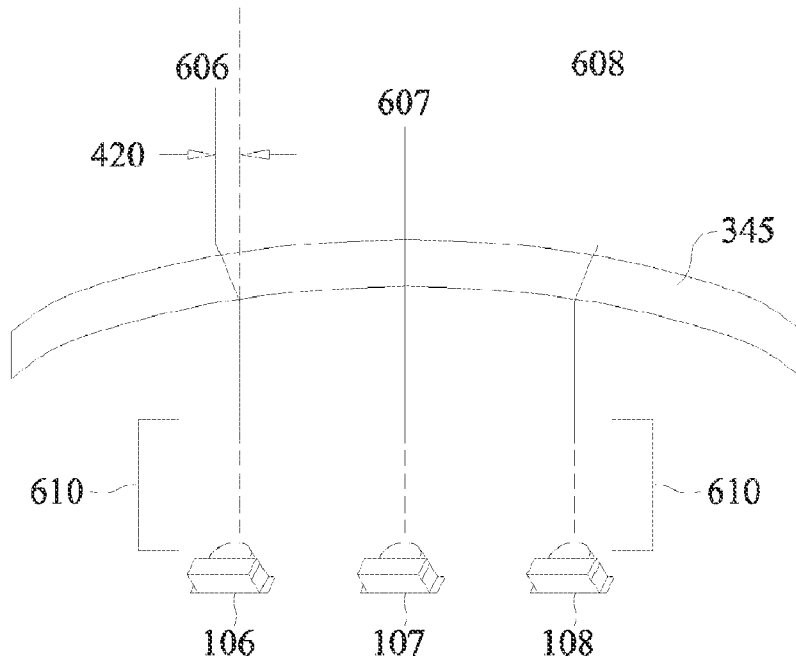

FIG. 26

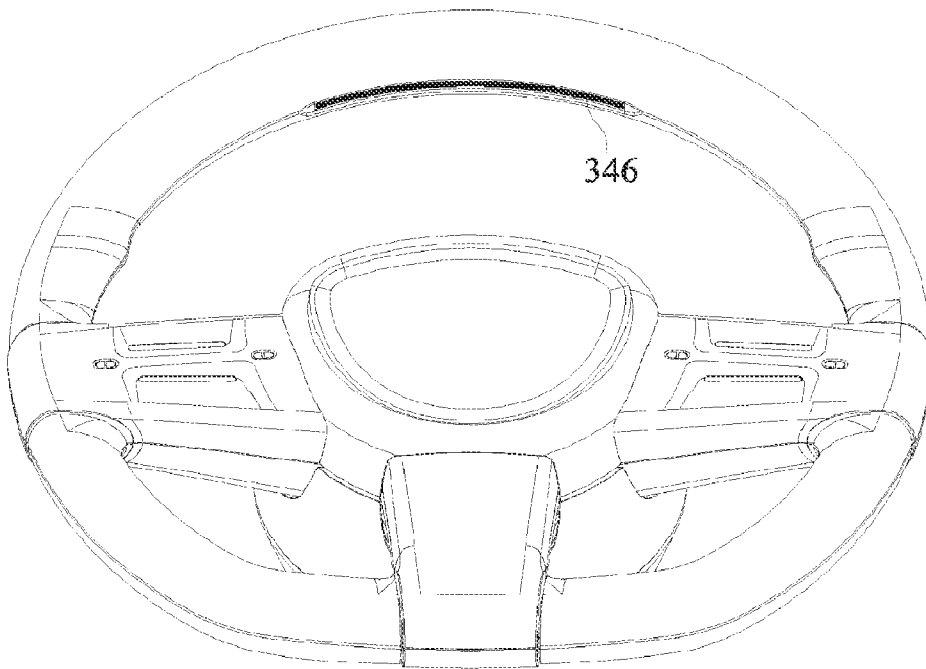

FIG. 27

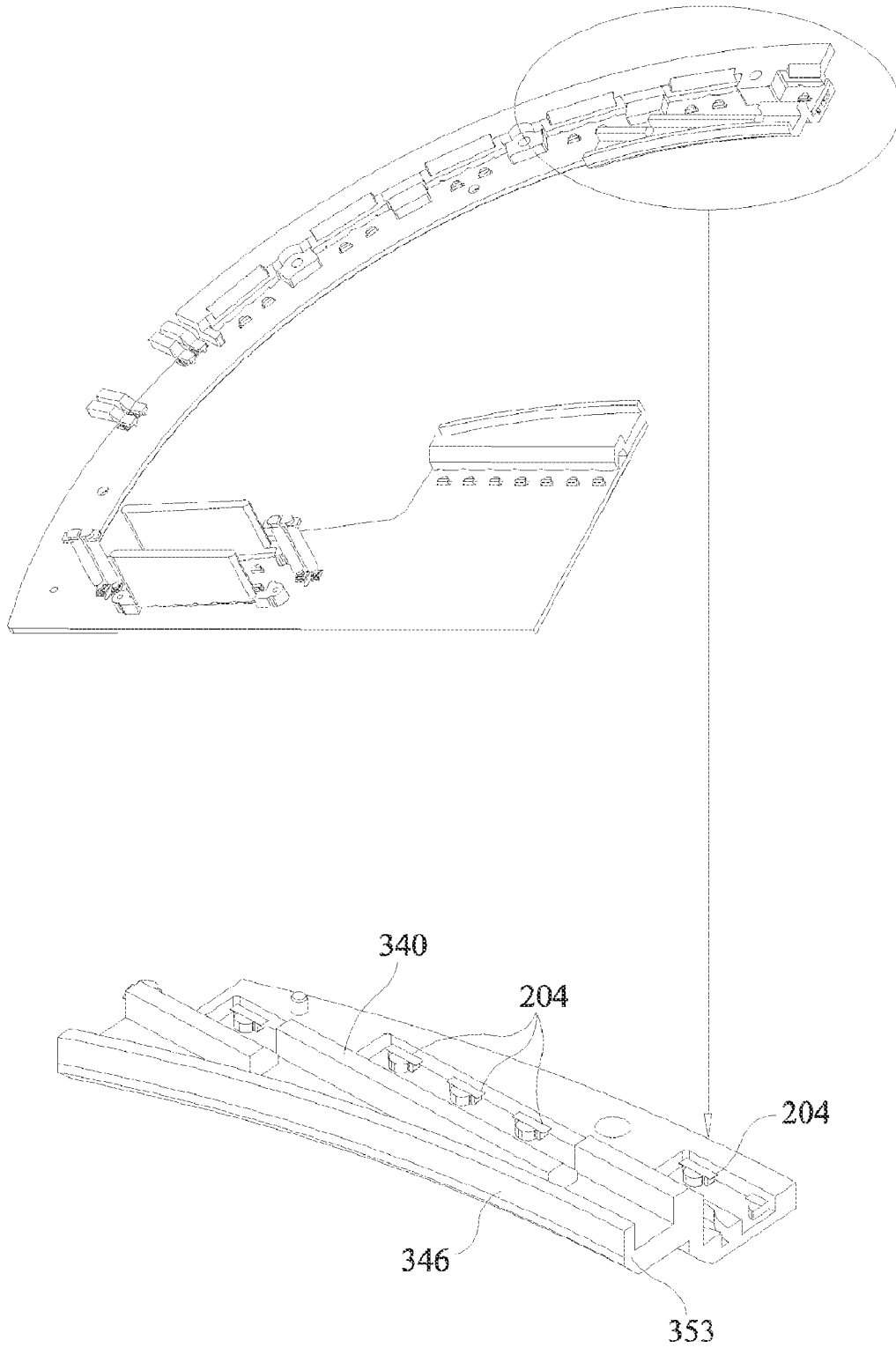

FIG. 28

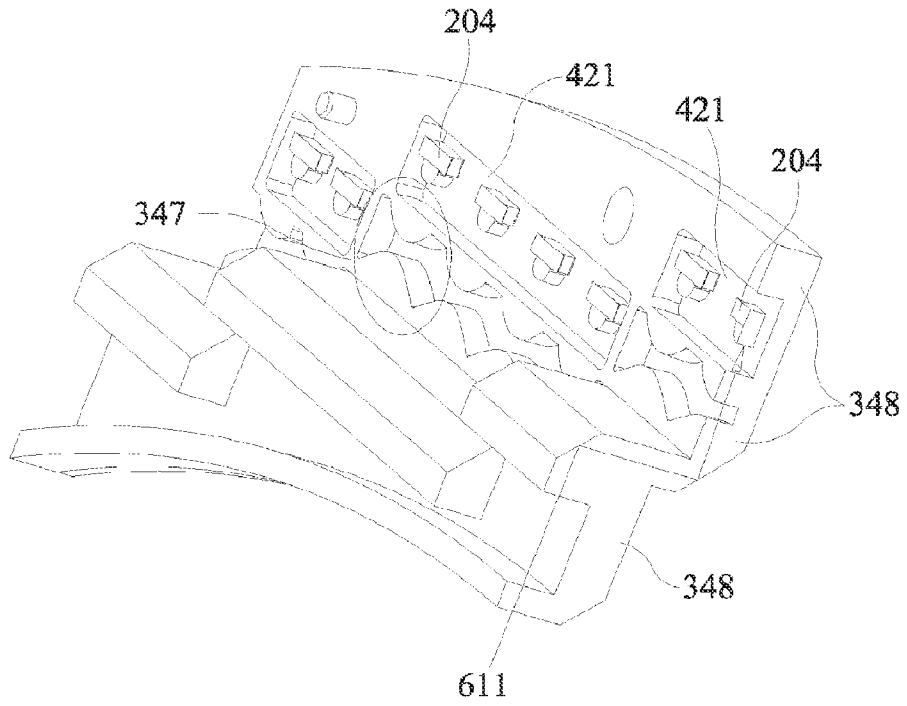

FIG. 29

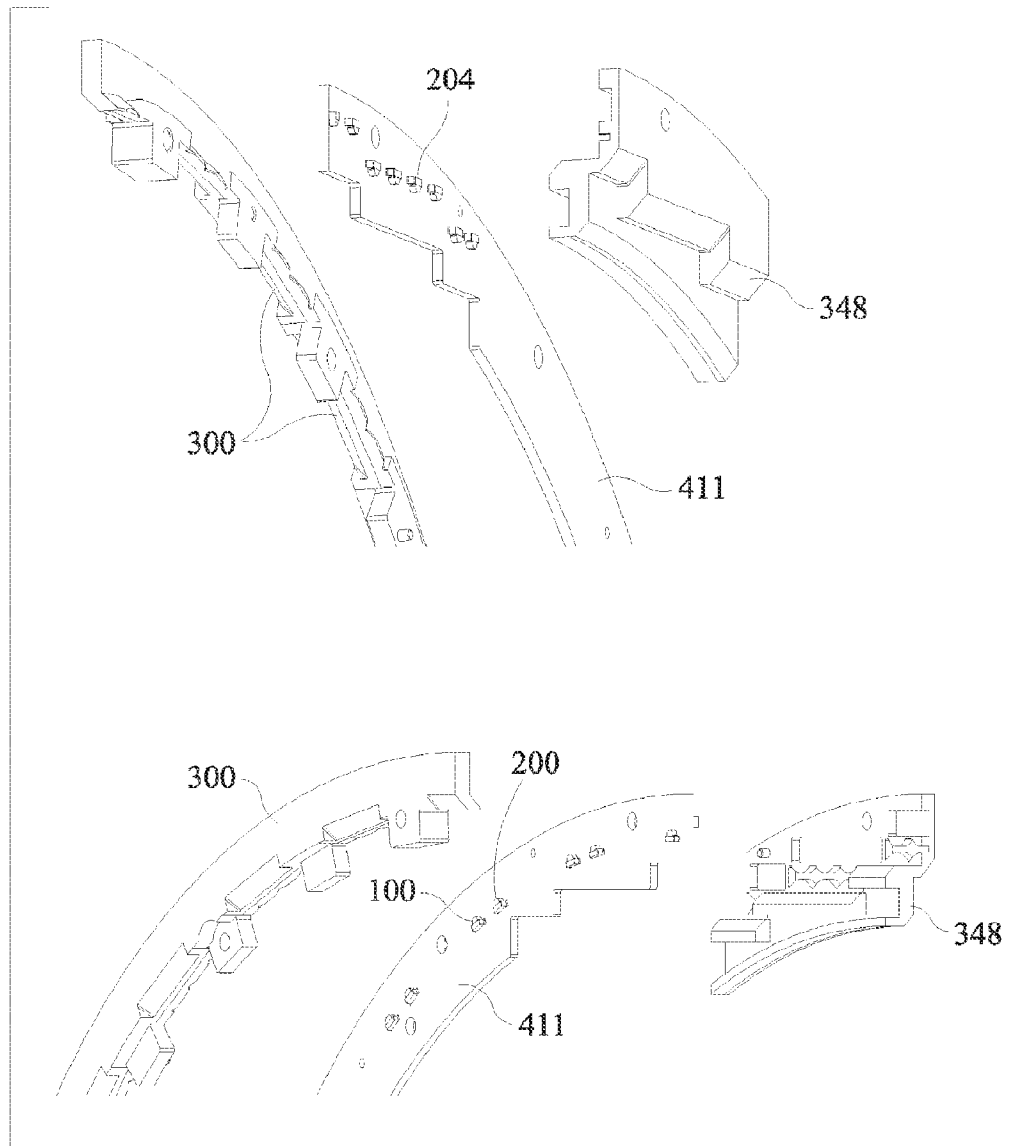

FIG. 30

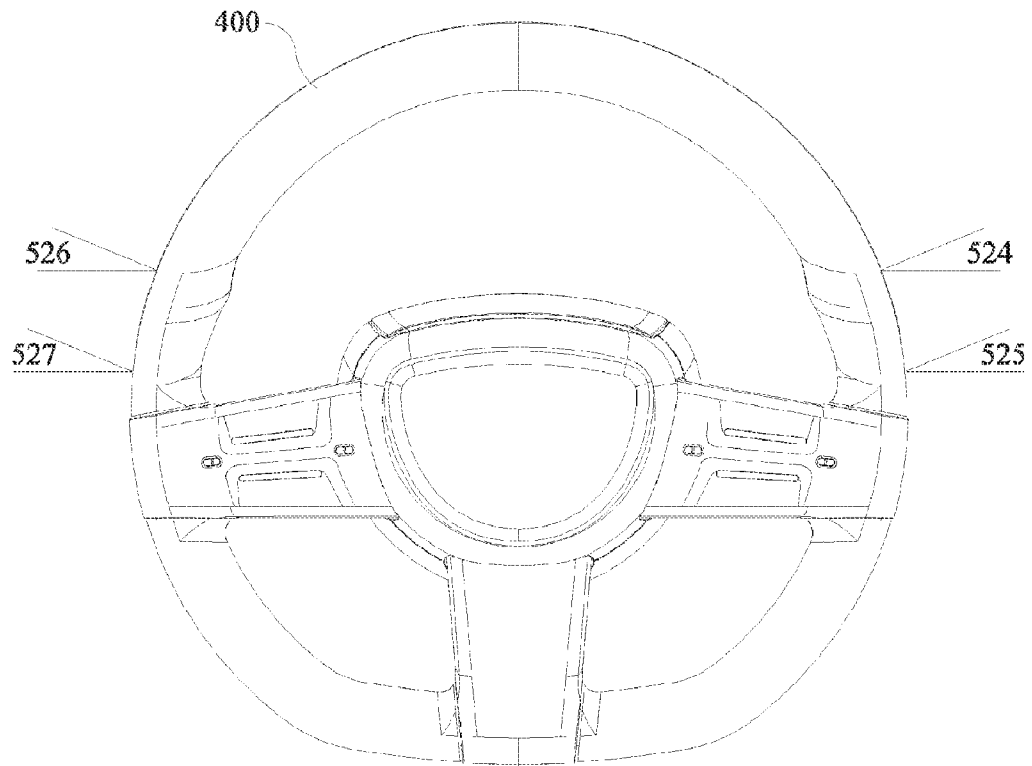

FIG. 31

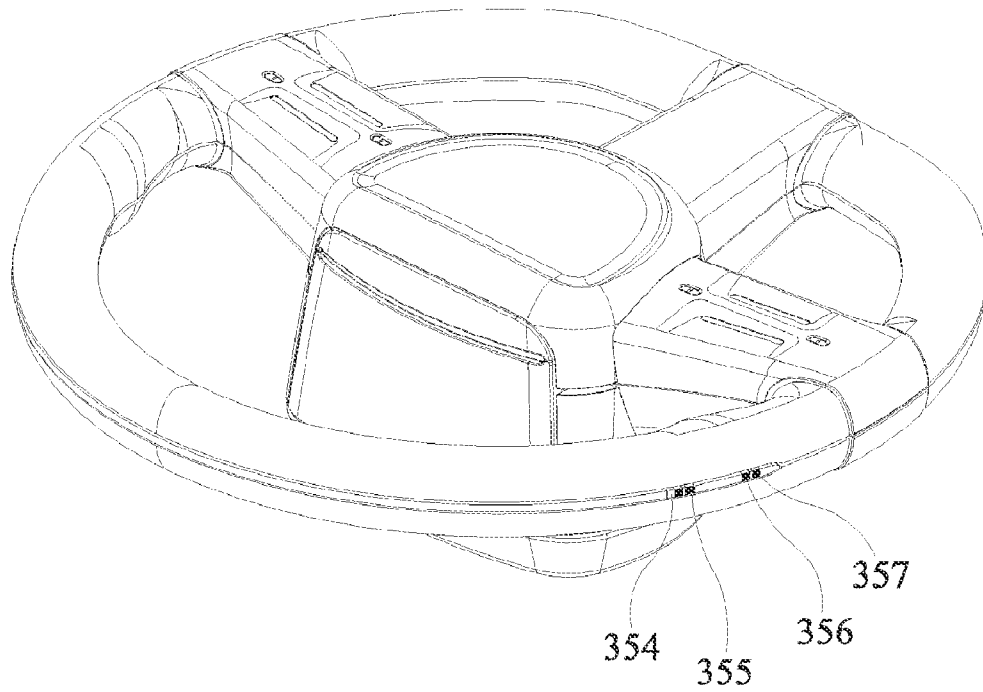

FIG. 32

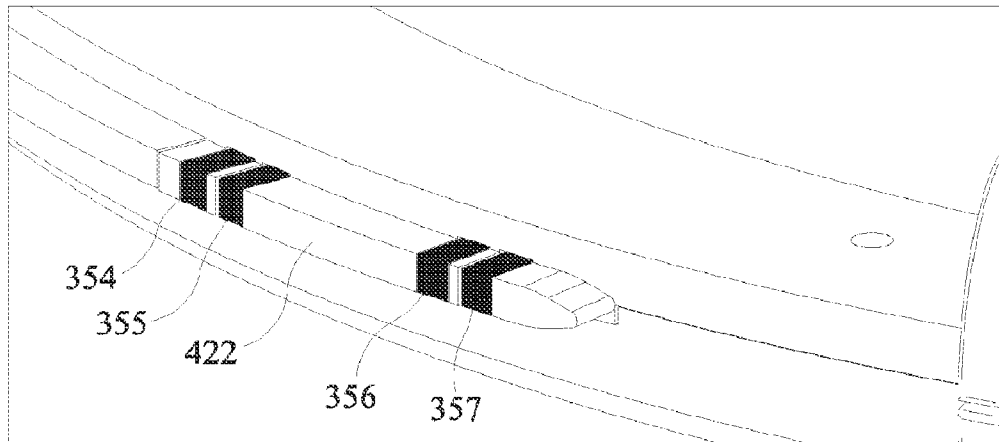

FIG. 33

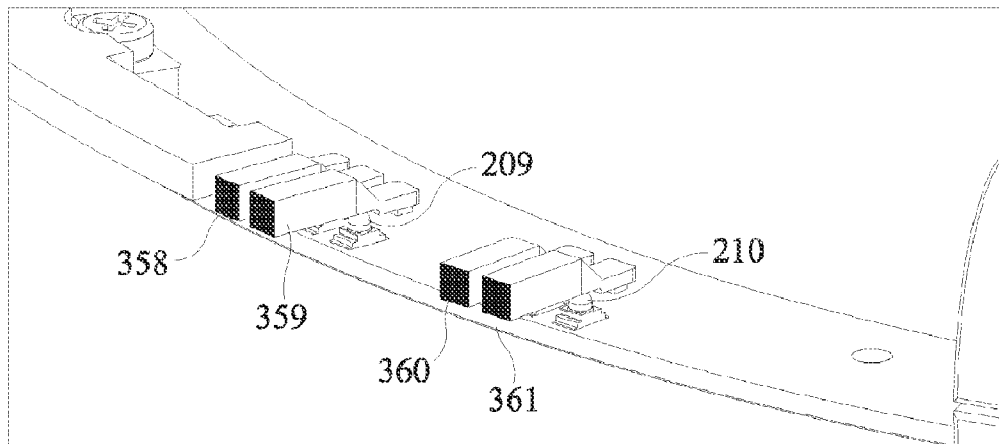

FIG. 34

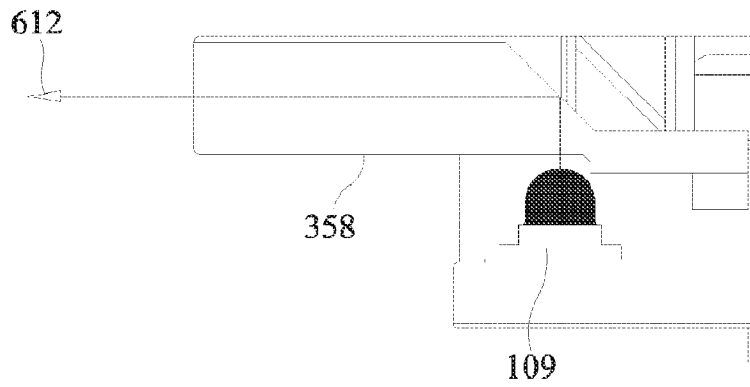

FIG. 35

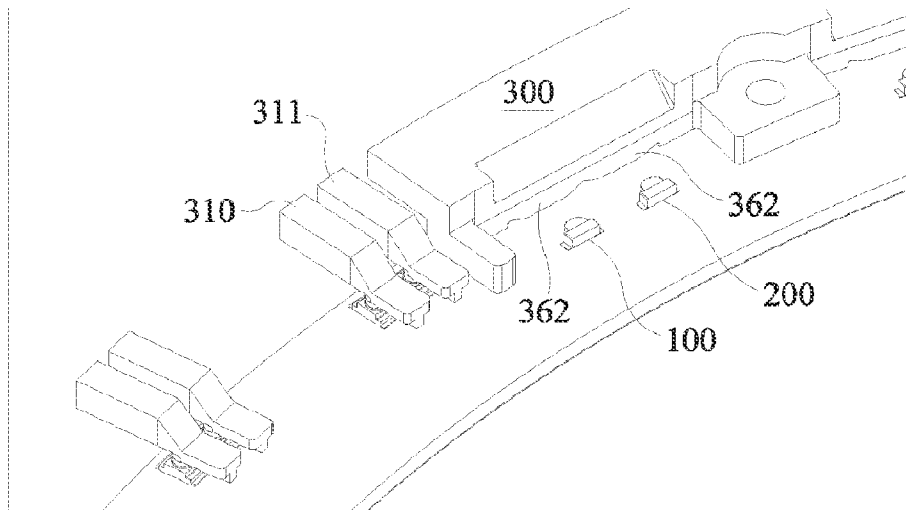

FIG. 36

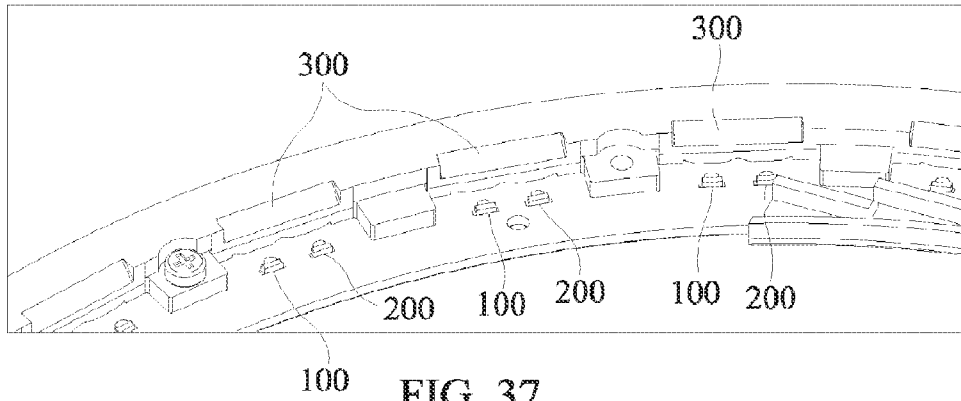

FIG. 37

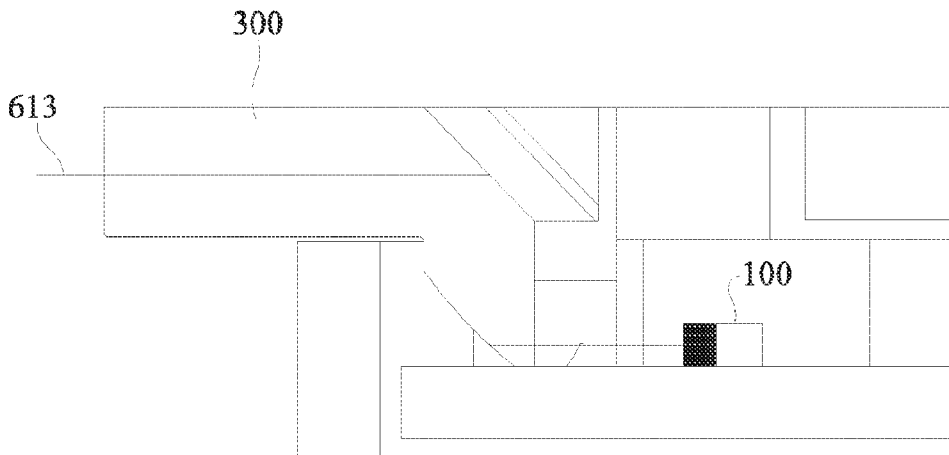

FIG. 38

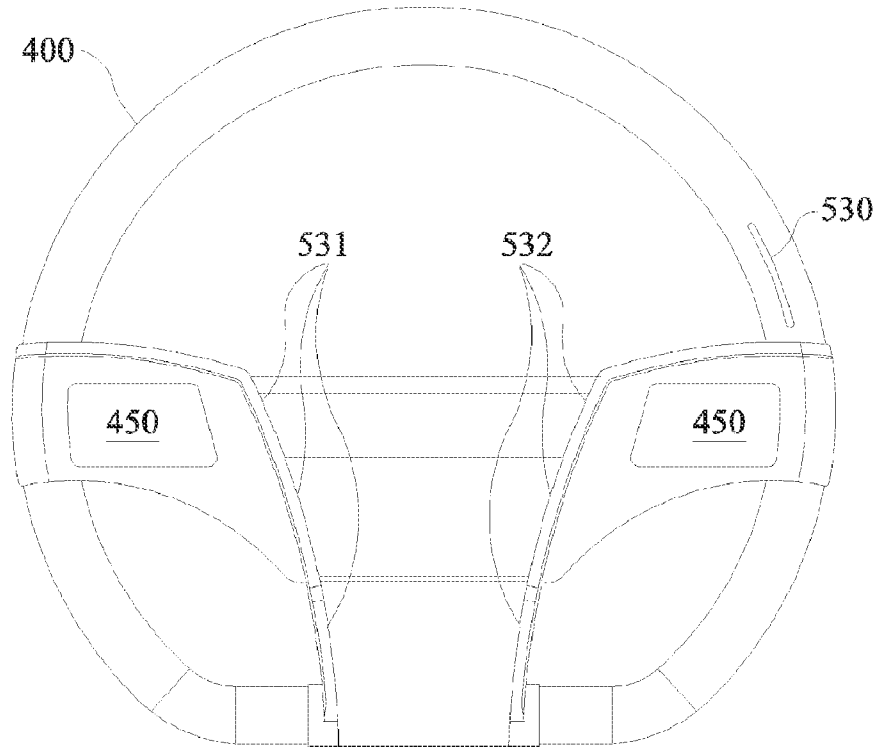

FIG. 39

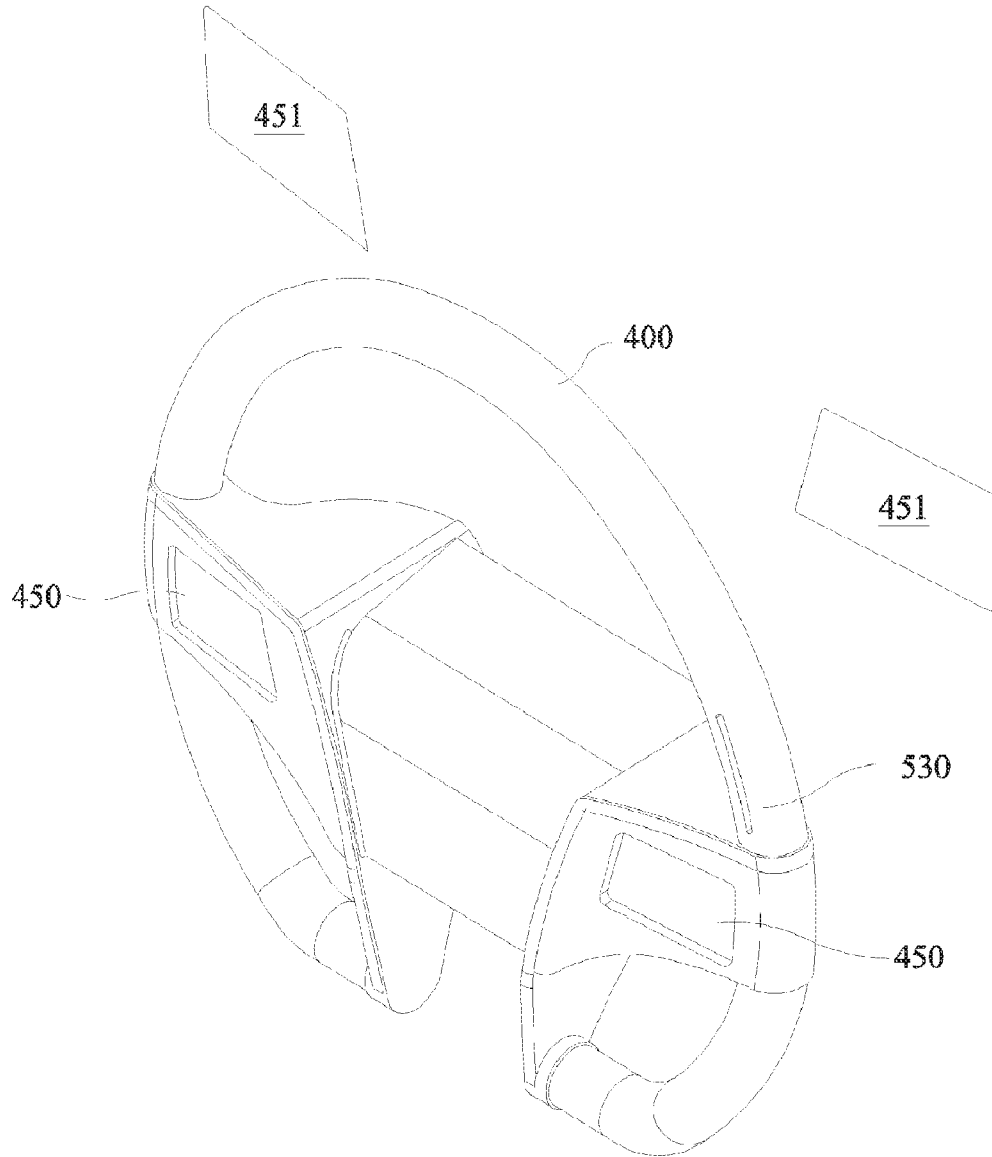

FIG. 40

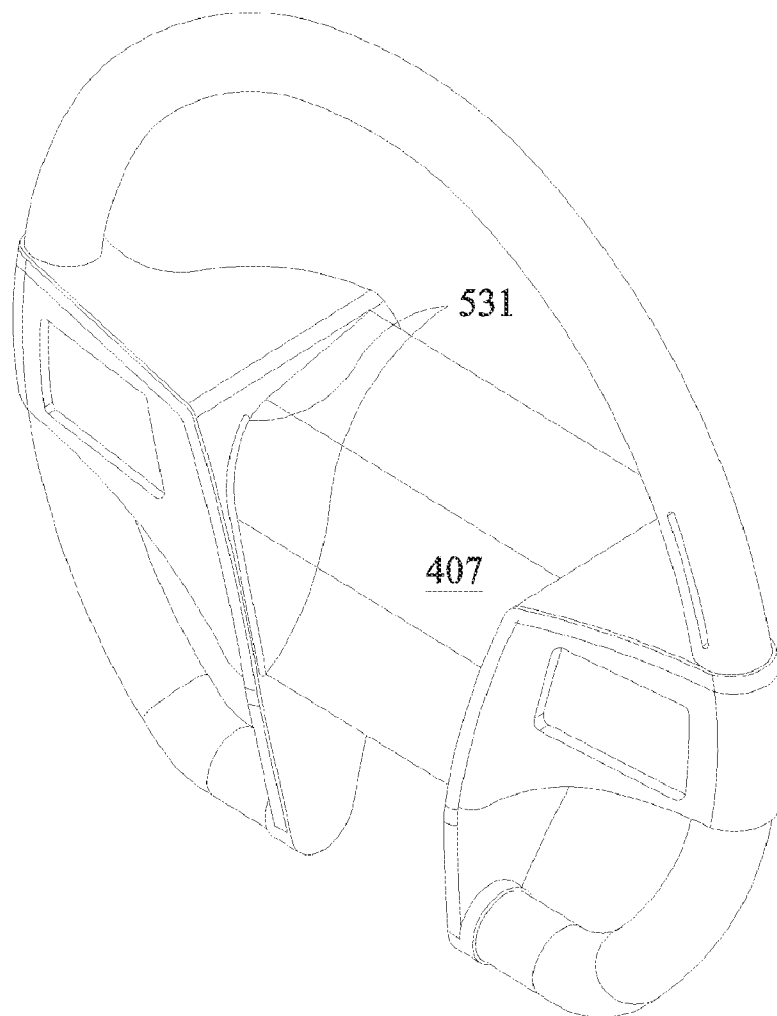

FIG. 41

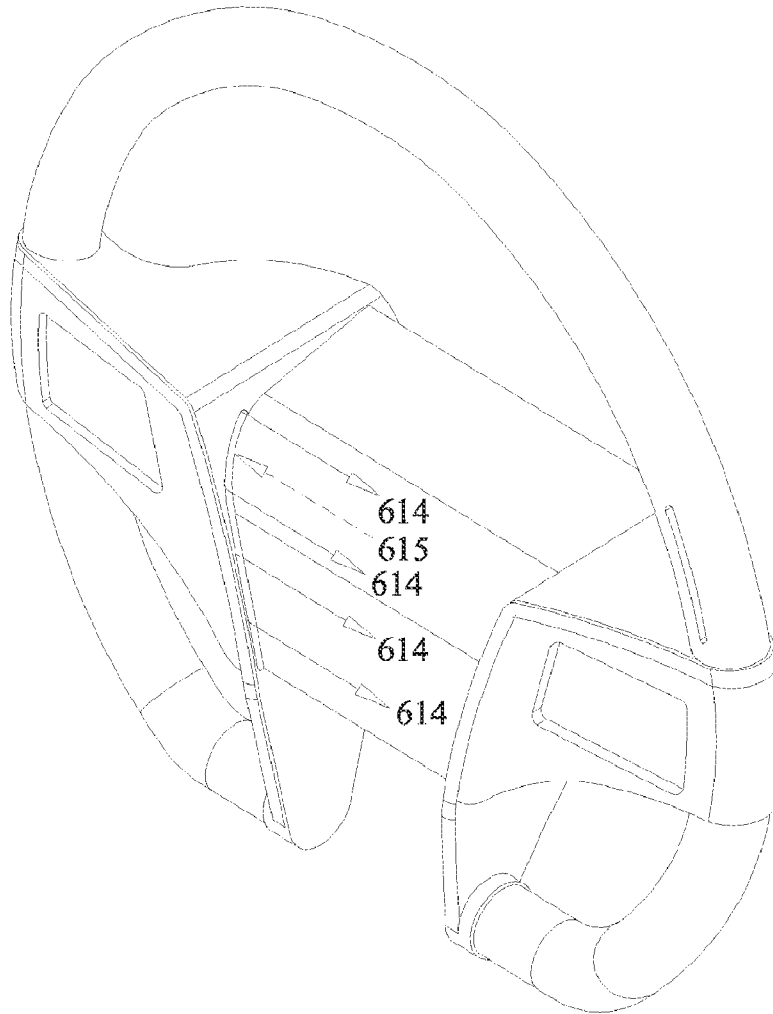

FIG. 42

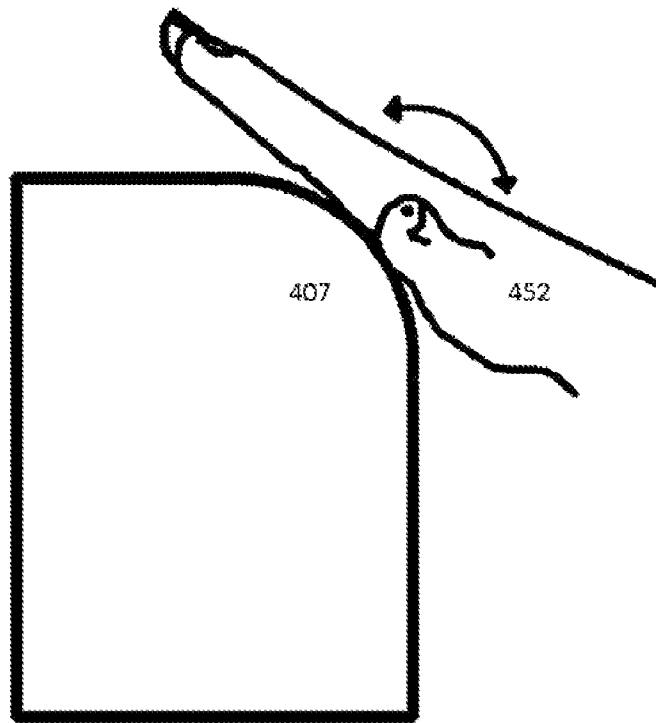

FIG. 43

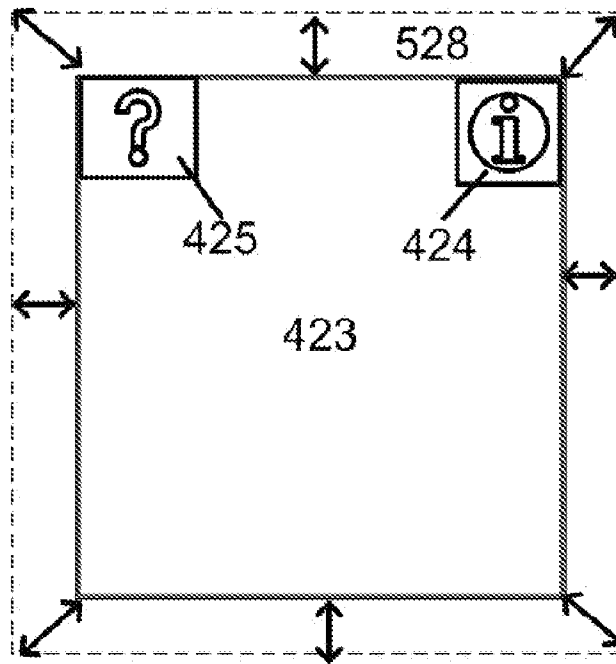

FIG. 44

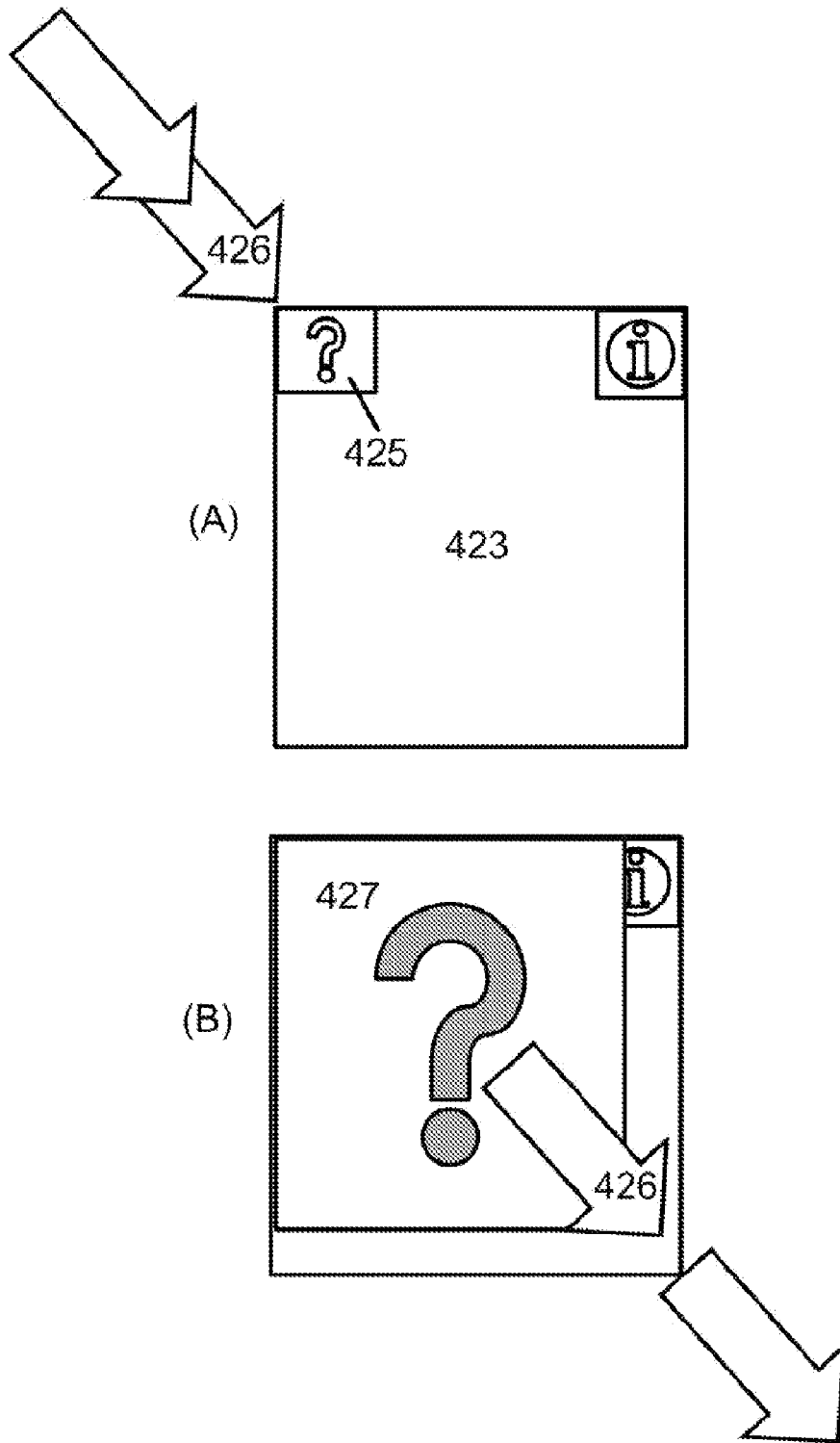

FIG. 45

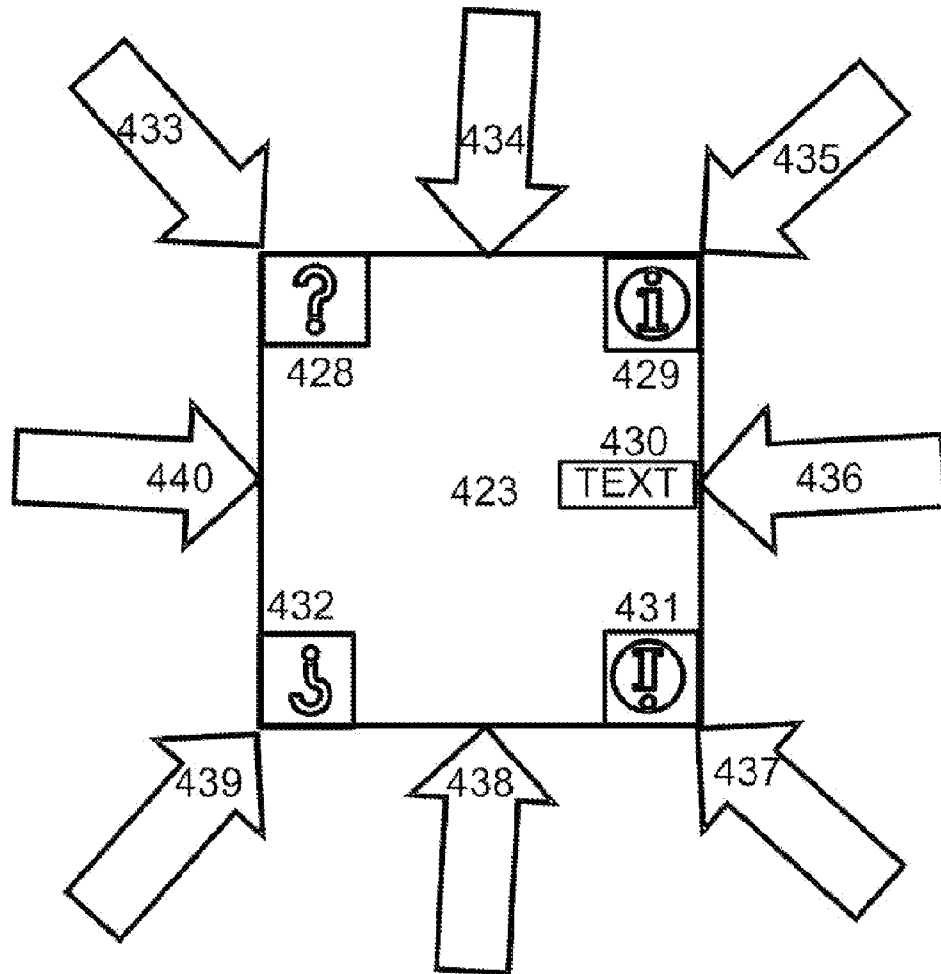

FIG. 46

LIGHT-BASED TOUCH CONTROLS ON A STEERING WHEEL

CROSS REFERENCES TO RELATED APPLICATIONS

This application is a non-provisional of U.S. Provisional Application No. 61/730,139, entitled LIGHT-BASED TOUCH CONTROLS ON A STEERING WHEEL AND DASHBOARD, and filed on Nov. 27, 2012 by inventors Gunnar Martin Fröjd, Thomas Eriksson, John Karlsson, Maria Hedin and Richard Berglind, the contents of which are hereby incorporated herein in their entirety.

This application is also a continuation-in-part of U.S. application Ser. No. 13/854,074, entitled LIGHT-BASED FINGER GESTURE USER INTERFACE, and filed on Mar. 30, 2013 by inventors Thomas Eriksson, Per Leine, Jochen Laveno Mangelsdorff, Robert Pettersson and Anders Jansson, the contents of which are hereby incorporated herein in their entirety.

This application is also a continuation-in-part of U.S. application Ser. No. 13/775,269 entitled REMOVABLE PROTECTIVE COVER WITH EMBEDDED PROXIMITY SENSORS, and filed on Feb. 25, 2013 by inventors Thomas Eriksson, Stefan Holmgren, John Karlsson, Remo Behdasht, Erik Rosengren and Lars Sparf, the contents of which are hereby incorporated herein in their entirety.

This application is also a continuation-in-part of U.S. application Ser. No. 13/424,543, entitled OPTICAL ELEMENTS WITH ALTERNATING REFLECTIVE LENS FACETS, and filed on Mar. 20, 2012 by inventors Stefan Holmgren, Lars Sparf, Magnus Goertz, Thomas Eriksson, Joseph Shain, Anders Jansson, Niklas Kvist, Robert Pettersson and John Karlsson, the contents of which are hereby incorporated herein in their entirety.

U.S. application Ser. No. 13/854,074 is a continuation of U.S. Ser. No. 13/424,592, entitled LIGHT-BASED FINGER GESTURE USER INTERFACE, and filed on Mar. 20, 2012 by inventors Thomas Eriksson, Per Leine, Jochen Laveno Mangelsdorff, Robert Pettersson and Anders Jansson, now U.S. Pat. No. 8,416,217, the contents of which are hereby incorporated herein in their entirety.

U.S. application Ser. No. 13/424,592 claims priority benefit of U.S. Provisional Application Ser. No. 61/564,868, entitled LIGHT-BASED FINGER GESTURE USER INTERFACE, and filed on Nov. 30, 2011 by inventors Thomas Eriksson, Per Leine, Jochen Laveno Mangelsdorff, Robert Pettersson and Anders Jansson, the contents of which are hereby incorporated herein in their entirety.

U.S. application Ser. No. 13/775,269 is a continuation-in-part of U.S. patent application Ser. No. 13/732,456 entitled LIGHT-BASED PROXIMITY DETECTION SYSTEM AND USER INTERFACE, and filed on Jan. 3, 2013 by inventors Thomas Eriksson and Stefan Holmgren, the contents of which are hereby incorporated herein in their entirety.

U.S. application Ser. No. 13/424,543 claims priority benefit of U.S. Provisional Application Ser. No. 61/564,164, entitled OPTICAL ELEMENTS WITH ALTERNATIVE REFLECTIVE LENS FACETS, and filed on Nov. 28, 2011 by inventors Stefan Holmgren, Lars Sparf, Thomas Eriksson, Joseph Shain, Anders Jansson, Niklas Kvist, Robert Pettersson and John Karlsson, the contents of which are hereby incorporated herein in their entirety.

U.S. application Ser. No. 13/424,543 also claims priority benefit of PCT Application No. PCT/US11/29191, entitled LENS ARRANGEMENT FOR LIGHT-BASED TOUCH SCREEN, and filed on Mar. 21, 2011 by inventors Magnus

Goertz, Thomas Eriksson, Joseph Shain, Anders Jansson, Niklas Kvist, Robert Pettersson, Lars Sparf and John Karlsson, the contents of which are hereby incorporated herein in their entirety.

U.S. application Ser. No. 13/424,543 is also a continuation-in-part of U.S. application Ser. No. 12/371,609, entitled LIGHT-BASED TOUCH SCREEN, and filed on Feb. 15, 2009 by inventors Magnus Goertz, Thomas Eriksson and Joseph Shain, now U.S. Pat. No. 8,339,379, the contents of which are hereby incorporated herein in their entirety.

U.S. application Ser. No. 13/424,543 is also a continuation-in-part of U.S. application Ser. No. 12/760,567, entitled OPTICAL TOUCH SCREEN SYSTEMS USING REFLECTED LIGHT, and filed on Apr. 15, 2010 by inventors Magnus Goertz, Thomas Eriksson and Joseph Shain, the contents of which are hereby incorporated herein in their entirety.

U.S. application Ser. No. 13/424,543 is also a continuation-in-part of U.S. application Ser. No. 12/760,568, entitled OPTICAL TOUCH SCREEN SYSTEMS USING WIDE LIGHT BEAMS, and filed on Apr. 15, 2010 by inventors Magnus Goertz, Thomas Eriksson and Joseph Shain, the contents of which are hereby incorporated herein in their entirety.

PCT Application No. PCT/US11/29191 claims priority benefit of U.S. Provisional Application Ser. No. 61/379,012, entitled OPTICAL TOUCH SCREEN SYSTEMS USING REFLECTED LIGHT, and filed on Sep. 1, 2010 by inventors Magnus Goertz, Thomas Eriksson, Joseph Shain, Anders Jansson, Niklas Kvist and Robert Pettersson, the contents of which are hereby incorporated herein in their entirety.

PCT Application No. PCT/US11/29191 also claims priority benefit of U.S. Provisional Application Ser. No. 61/380,600, entitled OPTICAL TOUCH SCREEN SYSTEMS USING REFLECTED LIGHT, and filed on Sep. 7, 2010 by inventors Magnus Goertz, Thomas Eriksson, Joseph Shain, Anders Jansson, Niklas Kvist and Robert Pettersson, the contents of which are hereby incorporated herein in their entirety.

PCT Application No. PCT/US11/29191 also claims priority benefit of U.S. Provisional Application Ser. No. 61/410,930, entitled OPTICAL TOUCH SCREEN SYSTEMS USING REFLECTED LIGHT, and filed on Nov. 7, 2010 by inventors Magnus Goertz, Thomas Eriksson, Joseph Shain, Anders Jansson, Niklas Kvist, Robert Pettersson and Lars Sparf, the contents of which are hereby incorporated herein in their entirety.

U.S. application Ser. No. 12/760,567 claims priority benefit of U.S. Provisional Application Ser. No. 61/169,779, entitled OPTICAL TOUCH SCREEN, and filed on Apr. 16, 2009 by inventors Magnus Goertz, Thomas Eriksson and Joseph Shain, the contents of which are hereby incorporated herein in their entirety.

FIELD OF THE INVENTION

The field of the present invention is light-based user interfaces for vehicles.

BACKGROUND OF THE INVENTION

Reference is made to FIG. 1, which is a simplified illustration of prior art steering wheel. A prior art steering wheel 400, shown in FIG. 1, includes a circular gripping member 401, one or more connecting members 402-404 that connect the gripping member 401 to steering column 407, and buttons 405 and 406 on connecting members 402 and 403 for controlling various devices in the vehicle. Connecting members 402-404, which connect gripping member 401 to steering column 407, are also referred to as spokes. In FIG. 1, button

405 is used to answer an incoming phone call on the vehicle's BLUETOOTH® speaker phone and button 406 hangs up the call. BLUETOOTH is a trademark owned by the Bluetooth SIG of Kirkland, Wash., USA. Controls mounted in a steering wheel can be operated comfortably and safely since the driver is able to control and operate these controls without taking hands off the wheel or eyes off the road.

Originally, the first button added to a steering wheel was a switch to activate the car's electric horn. When cruise control systems were introduced, some automakers located the operating switches for this feature on the steering wheel as well. Today additional button controls for an audio system, a telephone and voice control system, a navigation system, a stereo system, and on board computer functions are commonly placed on the steering wheel.

US Patent Publication No. 2012/0232751 A1 for PRESURE SENSITIVE STEERING WHEEL CONTROLS teaches adding pressure-sensitive controls to the circular gripping member of the steering wheel. Pressure sensors are located at various locations along the perimeter of the gripping member, and different locations correspond to different controls. A control is actuated in response to an application of pressure at a sensor location, e.g., by the user tightening his grip.

Many present-day vehicle dashboard consoles involve much more than simply displaying information to the driver. The driver, in many instances, is required to navigate a series of touch screen menus and icons in order to operate the dashboard console.

SUMMARY

The present invention relates to buttons and controls mounted in a steering element and associated dashboard user interfaces. More broadly, the present invention relates to remote controls for on board vehicle systems and associated user interfaces. The term "steering element" in the context of the present specification includes any physical element used to navigate a vehicle, such as a steering wheel, aircraft yoke, side-sticks and center-sticks, ship's wheel, bicycle or motorcycle handle bars.

Embodiments of the present invention provide a sensor system that detects position, proximity and pressure, separately or in combination, to enable input of complex gestures on and around a steering element. In some embodiments, the sensor system of the present invention is used in conjunction with a head-up display (HUD) or wearable goggles with built in picture presentation. In this case, the HUD or goggles render icons or a grid in the user's field of view. The user extends his hand to interact with the rendered image elements. The sensor detects the user's gestures in 3D space and these coordinates are then mapped onto the rendered image to interpret the user input.

Embodiments of the present invention also provide a dashboard coupled with a sensor system that utilizes the dashboard display for relevant information without cluttering the dashboard with buttons. The sensor system detects position, proximity and direction for input of complex gestures on the dashboard. In some embodiments, the dashboard is presented to the driver through a HUD or wearable goggles with built in picture presentation. In this case the sensor system enables the driver to interact with graphics presented by the HUD or goggles, by detecting the driver hand gestures and mapping them onto the projected HUD or goggle images. Embodiments of the present invention facilitate operation of the vehicle dashboard system by eliminating irrelevant information from the display. Moreover, a user interface in accor-

dance with the present invention provides context-relevant options, namely, options related to the state and circumstances of the vehicle. E.g., the user interface presents parking options when the user stops the vehicle, and presents options to unlock various doors, such as the trunk and gas tank, when the motor is turned off.

The present invention relates to a motor vehicle, that includes a steering wheel situated opposite a driver seat in the motor vehicle, the steering wheel including a plurality of proximity sensors encased in the periphery of the steering wheel for detecting hand slide gestures along the outer periphery of the steering wheel, an entertainment and navigation system housed in a dashboard in the vehicle, and, a processor housed in the vehicle and connected to the sensors and to the entertainment and navigation system for controlling the entertainment and navigation system in response to the detected hand slide gestures.

In some embodiments, in response to a detected upward slide gesture the processor increases an adjustable setting for the entertainment and navigation system and in response to a detected downward slide gesture the processor decreases the adjustable setting.

In some embodiments, the entertainment and navigation system includes a plurality of adjustable features, wherein a setting for a selected feature is adjusted in response to the hand slide gestures, and wherein the processor changes the selected feature in response to at least one tap on the outer periphery of the steering wheel. When the processor changes the selected feature, a graphic indicating the newly selected feature is rendered on a display connected to the entertainment and navigation system, such as a dashboard-mounted display or HUD. In some embodiments, this display is situated inside goggles worn by the driver. Examples of adjustable settings include raising or lowering the audio volume, selecting a radio channel and selecting a track in a music library, bass, treble, image view in a GPS system—e.g., 2D view, 3D view, satellite view, and zooming an image.

In some embodiments, a second plurality of proximity sensors encased in the steering wheel facing the driver, detects hand wave gestures between the steering wheel and the driver, wherein the processor changes a mode of the entertainment and navigation system in response to the hand wave gestures. This said second plurality of proximity sensors is also operative to detect the driver entering the motor vehicle.

In some embodiments, the steering wheel further comprises a cavity, i.e., an air gap, an array of light emitters connected to the processor that project light beams across the cavity and an array of light detectors connected to the processor that detect the projected light beams. This enables detecting wave gestures inside the cavity that interrupt the light beams, which allows the user to control the entertainment and navigation system through these detected gestures inside the cavity. These wave gestures are performed by one or more fingers or by the palm of a hand.

In some embodiments having a steering wheel cavity, there are multiple arrays of light emitters connected to the processor that project light beams at different geometric planes across the cavity and multiple arrays of light detectors connected to the processor that detect the projected light beams, for detecting wave gestures across multiple geometric planes inside the cavity that interrupt the light beams. This enables detecting wave gestures across a depth of the cavity for a wide range of wave gestures. For example, these sensors detect an angle at which the finger or hand penetrates the cavity. They also detect a velocity of approach by measuring the different times at which the finger or hand crosses each geometric

5

plane. In some embodiments of the cavity the light beams are all projected vertically across the cavity. In other embodiments, a bidirectional grid of light beams is projected across the cavity.

In order to prevent inadvertent adjusting of the entertainment system controls during driving, in certain embodiments the hand slide gestures control the entertainment and navigation system only when the steering wheel is not substantially rotated, namely, that it is at the "twelve-o'clock" position, or has not deviated more than a threshold amount from the "twelve-o'clock" position.

In some embodiments, the entertainment and navigation system includes a display, and the processor zooms an image on the display in response to detecting a spread gesture performed by two or more fingers in the cavity, and pans the image in response to a translation gesture performed by one or more fingers in the cavity. In some embodiments of the present invention, the finger spread gesture is performed by spreading or separating the tips of all fingers of one hand inside the cavity. In other embodiments of the present invention, the finger spread gesture is performed by extending all fingers of one hand inside the cavity. The image is, inter alia, a map related to the navigation system, a rear view camera image, or a graphic related to the entertainment system.

In some embodiments, the vehicle includes a wireless phone interface, inter alia a BLUETOOTH® interface, that is controlled using tap gestures or hand slide gestures on the outer perimeter of the steering wheel. For example, a single tap answers a call and a double-tap hangs up or declines the call.

In some embodiments, a sudden quick hand slide gesture along the outer periphery of the steering wheel mutes the entertainment and navigation system.

In some embodiments, when the processor changes the selected feature, the processor renders an image of the steering wheel on a display mounted in the vehicle, the image indicating which command is associated with each steering wheel input zone.

The present invention also relates to a motor vehicle having a dashboard display surrounded by a frame of proximity sensors for detecting wave gestures above the frame. A graphic representing a group of related functions is presented in a corner of the display. In response to a diagonal wave gesture above the frame beginning above this corner, the graphic is translated across the display revealing icons for the related functions. In some embodiments different graphics representing different groups of functions are presented in respective display corners, and a diagonal wave gesture beginning at a corner opens that corner's group of functions by translating the corresponding graphic diagonally across the display.

There is thus provided in accordance with an embodiment of the present invention, a system for use in a vehicle, including a steering element situated opposite a driver seat in a vehicle, the steering element including a plurality of proximity sensors encased in the periphery of the steering element operable to detect hand gestures along the outer periphery of the steering element, an interactive deck housed in the vehicle, for providing at least one of radio broadcast, video broadcast, audio entertainment, video entertainment and navigational assistance in the vehicle, and a processor housed in the vehicle, coupled with the proximity sensors and the deck, operable to identify the hand gestures detected by the proximity sensors, and to control the deck in response to thus-identified hand gestures.

There is additionally provided in accordance with an embodiment of the present invention a dashboard for a

6

vehicle, including a display, a frame including proximity sensors for detecting hand gestures above the frame, and a processor coupled with the display and the frame, operable to present a graphic representing a group of related functions in a corner of the display, and to identify the hand gestures detected by the proximity sensors, and wherein, in response to identifying a diagonal hand wave gesture above the frame and beginning above the corner of the display, the processor translates the graphic across the display thereby revealing icons for the related functions.

BRIEF DESCRIPTION OF THE DRAWINGS

The present invention will be more fully understood and appreciated from the following detailed description, taken in conjunction with the drawings in which:

FIG. 1 is a simplified illustration of prior art steering wheel;

FIG. 2 is a simplified illustration of a first embodiment of a steering wheel having multiple detection zones, in accordance with an embodiment of the present invention;

FIG. 3 is a simplified illustration of a second embodiment of a steering wheel having multiple detection zones, in accordance with an embodiment of the present invention;

FIG. 4 is a simplified illustration of a bidirectional light grid, namely, horizontal and vertical light beams, for detecting objects inserted into a hollow portion of the steering wheel of FIG. 3, in accordance with an embodiment of the present invention;

FIG. 5 is a simplified side view and profile view of the steering wheel of FIG. 3, in accordance with an embodiment of the present invention;

FIG. 6 is a flow chart describing a sequence of user interface events for adjusting car stereo controls, in accordance with an embodiment of the present invention;

FIG. 7 is a flow chart describing a sequence of user interface events for entering text, in accordance with an embodiment of the present invention;

FIG. 8 is a flow chart describing a sequence of user interface events for manipulating an image displayed on a car dashboard, in accordance with an embodiment of the present invention;

FIGS. 9-11 are simplified illustrations of a PCB assembly (PCBA) in a steering wheel, in accordance with an embodiment of the present invention;

FIGS. 12-16 are simplified diagrams of proximity sensors on a steering wheel, in accordance with an embodiment of the present invention;

FIGS. 17-20 are simplified illustrations of slider controls embedded in a steering wheel, in accordance with an embodiment of the present invention;

FIGS. 21-30 are simplified diagrams of sensors embedded in a steering wheel that detect gestures inside an open cavity in the steering wheel, in accordance with an embodiment of the present invention;

FIGS. 31-35 are simplified diagrams of proximity sensors embedded in the outer rim of a steering wheel, in accordance with an embodiment of the present invention;

FIGS. 36-38 are simplified diagrams of touch sensors embedded across the outer rim of a steering wheel, in accordance with an embodiment of the present invention;

FIG. 39 is a simplified illustration of a steering wheel with multiple touch sensors and embedded touch screen displays, in accordance with an embodiment of the present invention;

FIG. 40 is a simplified illustration of the steering wheel of FIG. 39 with a head-up display, in accordance with an embodiment of the present invention;

7

FIGS. 41 and 42 are simplified illustrations or proximity sensors that line the steering column of the steering wheel of FIG. 39, in accordance with an embodiment of the present invention;

FIG. 43 is a simplified illustration of a user interface gesture performed on the steering column of the steering wheel of FIG. 39, in accordance with an embodiment of the present invention; and

FIGS. 44-46 are simplified illustrations of user interfaces and associated sweep gestures that are enabled on a vehicle dashboard, in accordance with an embodiment of the present invention.

In the specification and figures, the following numbering scheme is used. Steps in flow charts are numbered between 1-99, light transmitters are numbered in the 100's, light receivers are numbered in the 200's, light guides and lenses are numbered in the 300's, miscellaneous items are numbered in the 400's, detection zones and sensors are numbered in the 500's, and light beams are numbered in the 600's. Like numbered elements are similar but not necessarily identical.

The following tables catalog the numbered elements and list the figures in which each numbered element appears.

Light Transmitters

Element	Figures
100	9, 30, 36, 37, 38
101	14, 15, 16
102	15
103	9, 19, 20
104	9, 23, 24, 25
106	26
107	26
108	26
109	35

Light Receivers

Element	Figures
200	9, 30, 36, 37, 38
201	14, 15
202	15
203	9, 19
204	28, 29, 30
209	35
210	35

Light Guides and Lenses

Element	Figures
300	9, 10, 11, 30, 36, 37, 38
310	9, 10, 11, 36
311	9, 10, 11, 36
320	9, 10, 11, 18, 19, 20
321	18
330	9, 10, 11, 14, 15, 16
331	9, 10, 11, 14, 15
332	13
333	13
334	13
335	14, 15
336	15
337	15
338	15
340	9, 10, 11, 28
341	9, 10, 11, 23, 24, 25

8

-continued

Light Guides and Lenses

Element	Figures
342	22
343	24, 25
344	23, 25
345	23, 24, 25, 26
346	27, 28
347	29
348	29, 30
353	28
354	32, 33
355	32, 33
356	32, 33
357	32, 33
358	34, 35
359	34
360	34
361	34
362	36

Miscellaneous Items

Element	Figures	Description
400	1, 9, 31, 39-43	steering wheel
401	1, 2	grip
402	1, 2	right spoke
403	1, 2	left spoke
404	1, 2	bottom spoke
405	1	answer button
406	1	reject button
407	1, 2, 41, 43	steering column
408	5	nominal range
409	5	nominal range
410	5	thickness of grip
411	9, 10, 11, 30	PCB
412	9	opening in steering wheel
413	16, 20	finger
414	17	recessed cavity wall
415	17	recessed cavity wall
416	17	recessed cavity wall
417	17	inclined surface
418	18	intermediate layer
419	18	narrow openings
420	26	beam offset
421	29	cavities for light receivers in light guide
422	33	plastic rim
423	44, 45, 46	dashboard display
424	44	icon
425	44, 45	icon
426	45	diagonal sweep gesture
427	45	icon
428	46	icon
429	46	icon
430	46	text
431	46	icon
432	46	icon
433	46	directional sweep gesture
434	46	directional sweep gesture
435	46	directional sweep gesture
436	46	directional sweep gesture
437	46	directional sweep gesture
438	46	directional sweep gesture
439	46	directional sweep gesture
440	46	directional sweep gesture
450	39, 40	Touch screen display
451	40	Head-up display
452	43	Hand

Detection Zones and Sensors		
Element	Figures	Description
501	2, 21	zone
502	2	zone
503	2	zone
504	2	zone
505	2	zone
506	2	zone
507	2	zone
508	2	zone
510	3	zone
511	3	zone
512	3	zone
513	3	zone
514	3	zone
515	3	zone
516	3	zone
517	3	zone
520	12	sensor
521	12	sensor
522	17	sensor
523	17	sensor
524	31	zone
525	31	zone
526	31	zone
527	31	zone
528	39	Zone
530	39, 40	Slider sensor
531, 532	39, 41	Proximity sensor strip

Light Beams		
Element	Figures	Description
600	4	light beam grid
601	16	light beam
602	16	light beam
603	16	light beam
604	20	light beam
605	25	light beam
606	26	light beam
607	26	light beam
608	26	light beam
610	26	portion of light beam
611	29	light beam
612	35	light beam
613	38	light beam
614	42	Proximity sensor beam
615	42	Proximity sensor reflected beam

DETAILED DESCRIPTION

Aspects of the present invention relate to light-based touch controls that allow a driver to keep his hands on a steering element while operating peripheral electronic devices in a vehicle.

Reference is made to FIG. 2, which is a simplified illustration of a first embodiment of a steering wheel having multiple detection zones, in accordance with an embodiment of the present invention. Shown in FIG. 2 is a steering wheel with multiple detection zones for user input, indicated by numbers in the figure. Detection properties for each zone are listed below.

Zone 501 is a portion of a cavity surrounded by gripping member 401 and the top of steering column 407. The present invention enables detection of user gestures in this cavity. An example gesture is sweeping a hand or finger horizontally across the cavity.

Zone 502 is related to a portion of the outer rim of gripping member 401. This zone is configured to receive sliding ges-

tures, where the driver slides a finger or hand along this portion of the outer rim. An example application for this gesture is to control the volume on the vehicle's audio system, where a clockwise hand-slide or sweep gesture increases the volume, a counterclockwise hand-slide or sweep gesture reduces the volume, and a fast hand-slide or sweep gesture along zone 502 mutes the audio. If the audio is on mute, a fast hand-slide or sweep gesture along zone 502 cancels the mute. Another application is to use hand-slide or sweep gestures to answer or reject an incoming phone call. In this case a hand-slide or sweep gesture in a first direction, e.g., clockwise, answers the call, and a hand-slide or sweep gesture in the opposite direction rejects the call.

Zones 503 and 504 are proximity sensor zones configured to detect movement of a hand in the detection zone which is the airspace several inches outward on either side of the steering wheel. An example application uses zone 503 for controlling the windshield wipers and zone 504 for controlling the directional signals, i.e., blinking lamps mounted near the left and right front and rear corners of a vehicle activated by the driver on one side of the vehicle at a time to advertise intent to turn or change lanes toward that side. In this example, the windshield wipers are activated, or their speed is increased, when an upward hand gesture is detected in zone 503, and the windshield wipers are slowed down or turned off when a downward hand gesture is detected in zone 503. Similarly, the right directional signal is activated when an upward hand gesture is detected in zone 504, and the left directional signal is activated when a downward hand gesture is detected in zone 504.

Another example application for zones 503 and 504 is modeled on Formula One sports cars, where the gear shifter is adapted to fit onto the steering wheel in the form of two paddles; depressing the right paddle shifts into a higher gear, while depressing the left paddle shifts into a lower one. In the present embodiment, a gesture corresponding to depressing the right paddle is detected in zone 503, and a gesture corresponding to depressing the left paddle is detected in zone 504.

Zones 505 and 506 are two touch and slider controls on the right connecting member 402. An additional two touch and slider controls (not numbered) are shown on the left connecting member 403. These zones receive touch gestures and glide gestures. A glide gesture includes the steps of a user touching this sensor and then sliding his finger along the sensor. Slider controls are suitable for selecting a value within a range, e.g., to adjust dashboard brightness or audio volume. A glide gesture in one direction gradually increases the value, and a glide gesture in the opposite direction gradually decreases the value.

These controls determine a location of a touch along the slider and are therefore suitable for touch gestures as well. For example, extended touches or taps can be used for selecting a value within a range, such as to adjust dashboard brightness or audio volume. A tap or touch at one end of the slider increases the value, and a tap or touch at the opposite end decreases the value.

Zones 507 and 508 are hover and proximity sensors, configured to detect objects that are opposite but not touching the steering wheel. One example application detects when a driver enters the vehicle. This can wake up the system and display a greeting message to the driver. In some embodiments of the present invention, these sensors detect a distance between the driver and the wheel, inter alia, in order to adjust the driver's air bags according to this distance; namely, a larger distance requires a greater degree of inflation.

An additional two hover and proximity sensors (not numbered) are shown on the left connecting member 403. In some

embodiments of the present invention, these zones are also configured to detect touch gestures. Another application for zones **507** and **508** is to select a user input mode. For example, zone **502** has two associated applications: a music library and a radio station selector. Hand-slide or sweep gestures along zone **502** either browse the music library or scan radio channels depending on the active mode. The active mode is toggled or selected by touching one of zones **507** and **508**. For example, a tap on zone **508** activates music library mode and a tap on zone **507** activates radio mode. Alternatively, a right-to-left wave gesture above zones **507** and **508** activates music library mode, and a left-to-right wave gesture above zones **507** and **508** activates radio mode.

In general, the different zones are coordinated to provide fluent and flexible navigation for a plurality of applications. The user selects an application by interacting with zones **507** and **508** and each of the other zones **501-506** is assigned an aspect of the active application. Each time an application is selected, an image of the steering wheel appears on the dashboard indicating which command is associated with each of the input zones.

Reference is made to FIG. **3**, which is a simplified illustration of a second embodiment of a steering wheel having multiple detection zones, in accordance with an embodiment of the present invention. The multiple detection zones for user input are indicated by numbers in the figure. Detection properties for each zone are listed below.

Zones **510-512** are air gaps in the steering wheel. A two-dimensional grid of light beams is projected into each air gap to detect any object inserted therein.

Reference is made to FIG. **4**, which is a simplified illustration of a bidirectional light grid, namely, horizontal and vertical light beams, for detecting objects inserted into a hollow portion of the steering wheel of FIG. **3**, in accordance with an embodiment of the present invention. Shown in FIG. **4** is a light-beam grid **600** in zone **511**.

In some embodiments more than one layer of light beams is projected into each air gap to provide a series of detections at different points along the thickness of the air gap.

Reference is made to FIG. **5**, which is a simplified side view and profile view of the steering wheel of FIG. **3**, in accordance with an embodiment of the present invention. FIG. **5** shows the steering wheel of FIGS. **3** and **4** in profile view and at an angle from above the wheel's upper right corner. Both views indicate thickness **410** of gripping member **401** along which the multiple light grids are stacked. This enables detecting an angle at which an object is inserted into the air gap. A full explanation of multiple detection layers and their use for z-axis coordinate detection is provided in U.S. Pat. No. 8,416,217 for LIGHT-BASED FINGER GESTURE USER INTERFACE, the contents of which are incorporated herein by reference.

Returning to FIG. **3**, detection zone **517** is a hovering space surrounding the outer perimeter of the steering wheel. Objects that enter zone **517** are detected by sensors embedded in the gripping member of the steering wheel.

Zones **513-515** detect the position of one or more objects touching, or in close proximity to, these zones. The range of proximity detection is indicated in FIG. **5** by nominal range **408**. In some embodiments zones **513-515** are also adapted to detect an amount of pressure applied by a touch object.

Zone **516** detects the position of one or more objects touching, or in close proximity to, it. The range of proximity detection is indicated in FIG. **5** by nominal range **409**. In some embodiments zone **516** is also adapted to detect an amount of pressure applied by a touch object.

In order to avoid inadvertent input to the detection zones while steering the vehicle, the touch-sensitive input system is activated only under particular conditions. For example, in order that the system register touch input the user first performs a specific touch gesture on one or more of the detection zones. As another example, the user must activate a toggle switch located away from the steering wheel before the detection zones register user input. Yet another example is that the position of the steering wheel enables touch input to be registered. For example, only when the steering wheel is in the "twelve o'clock" or neutral position the system registers input from the detection zones, whereas once the wheel is rotated a given number of degrees from the neutral position, the system actively monitors the detection zones but does not generate input to other devices.

A few use cases will demonstrate the user interface of the present invention. A first use case is adjusting the volume in the car stereo.

Reference is made to FIG. **6**, which is a flow chart describing a sequence of user interface events for adjusting car stereo controls, in accordance with an embodiment of the present invention. At step **10** the steering wheel is in neutral position to enable touch input. At step **11** the driver presses a location in zone **513** that activates controls for the entertainment system. The first parameter to be adjusted by the controls is the volume. At step **12** a volume meter is presented on a display device such as a dashboard display or HUD. The driver adjusts the volume level by performing a hand-slide or sweep gesture along the right outer rim of the steering wheel, i.e., the right section of zone **517**. Steps **13-16** show that a counterclockwise gesture along the right hand side of detection zone **517** increases the volume, and a clockwise gesture along this zone decreases the volume. This counterclockwise gesture can be performed by raising the driver's right hand along the steering wheel. At step **17** one or more taps on the outside of the steering wheel (zone **517**) puts the input system into a different mode, e.g., to adjust the bass or treble. The system then returns to step **12** where it displays a meter relevant for the active mode, e.g., bass or treble, instead of volume. While the right hand is performing gestures that activate system functions, the left hand can perform additional gestures in the detection zones that do not interfere with the right hand gestures. In some instances these left hand gestures do not generate any commands.

A second use case is text input of an address to a vehicle navigation system.

Reference is made to FIG. **7**, which is a flow chart describing a sequence of user interface events for entering text, in accordance with an embodiment of the present invention. At step **20** the driver presses a location on zone **514** marked by a text input symbol to activate text input mode. At steps **21** and **22**, gestures inside zone **510** are interpreted as characters or symbols. Alternatively, characters are input by finger or stylus glide gestures on the surface of zone **516**. At step **23** the entered text is displayed on the dashboard or HUD. Steps **21-23** continue in a loop until the displayed text forms a name or word (or portion thereof). To confirm the input, the driver taps once on the outer rim of the steering wheel (zone **517**) as indicated by step **24**. To delete or reject the input, the driver double-taps on the outer rim of the steering wheel (zone **517**) as indicated by step **25**. The system operates independently of right/left handedness.

A third use case is an image viewer.

Reference is made to FIG. **8**, which is a flow chart describing a sequence of user interface events for manipulating an image displayed on a car dashboard, in accordance with an embodiment of the present invention. At step **30** an image is

displayed on the dashboard. Alternatively, this image is displayed on an HUD. This image may be a map, a rear-view camera viewfinder image or any other image. At step 31 the driver activates image manipulation mode, e.g., by tapping a location on zone 515 marked by an image symbol. At steps 32-34 hand movements in detection zone 511 are interpreted as image manipulation commands. These commands include panning, zooming and rotating the image. The hand movements supported include one-finger and multi-finger translation gestures, and two-finger pinch, two-finger spread and two-finger rotation gestures. Further hand movements supported include full-hand spreads, whereby a user spreads all fingers on one hand inside the air gap. Other supported gestures include full-hand pinch gestures, which begin when all fingertips of one hand are not touching each other, and the user draws his fingertips together. When multiple layers of light-beam guides provide z-axis detection, tilt gestures are also supported. A tilt gesture uses the angle at which a finger is inserted through air gap 511 as one of the gesture attributes. A full discussion of supported gestures and commands is included in the aforementioned U.S. Pat. No. 8,416,217 for LIGHT-BASED FINGER GESTURE USER INTERFACE. The driver taps once on the outer rim of the steering wheel (zone 517) to accept an input, as indicated at step 35, and taps twice on the outer rim of the steering wheel (zone 517) to cancel an input as indicated at step 36. This system operates independently of right/left handedness.

Discussion now turns to implementing sensors for each of the various detection zones. Generally speaking, a light-based touch or proximity sensor includes a light transmitter and a light receiver, and is based on the principle that an object such as a finger placed on or near the sensor changes the coupling of light between the transmitter and the receiver. Thus, a channel that conducts signals between the transmitter and the receiver indicates whether there is a touch inside the channel. There are two types of channels; namely,

- A. channels for which a finger activates a signal between the transmitter and the receiver; and
- B. channels for which a finger blocks a signal between the transmitter and the receiver.

For channels of type A, a low signal, near 0, indicates no touch, and a high signal indicates a touch. For channels of type B, a high signal indicates no touch, and a low signal, near 0, indicates a touch.

Reference is made to FIGS. 9-11, which are simplified illustrations of a PCB assembly (PCBA) in a steering wheel, in accordance with an embodiment of the present invention. FIGS. 9-11 show a printed circuit board assembly (PCBA) 411 populated with various touch and proximity sensor components for a steering wheel 400 according to embodiments of the present invention. FIG. 9 shows the PCBA from above, FIG. 10 shows the PCBA rotated, and FIG. 11 shows a cross-sectional view, to show the three-dimensional features of the light guides. The embodiment illustrated in FIGS. 9-11 includes five different sensor systems.

A first sensor system provides detection zones 507 and 508 in FIG. 2. Each sensor in this first system includes a pair of light guides 330 and 331, as shown in FIGS. 9-11. Light guide 330 is coupled to a transmitter (not shown) and light guide 331 is coupled to a receiver (also not shown). When a driver hovers his hand above one of these sensors he generates a high signal as his hand reflects light from light guide 330 back into light guide 331. This is a type A channel. In some embodiments similar sensors placed along spokes 402-404 that connect the gripping member 401 of wheel 400 to the steering column 407 are used to provide detection zones 513-515 in FIG. 3. Similar sensors placed inside steering column 407 of

wheel 400 also provide detection zone 516 in FIG. 3, in certain embodiments of the invention.

A second sensor system provides detection zones 505 and 506 in FIG. 2. Each sensor in this second system includes an alternating row of transmitters 103 and receivers 203, coupled to a light guide 320, as shown in FIGS. 9-11. When a driver touches the upper edge of light guide 320 he generates a high signal as his touch reflects light from one or more of transmitters 103 onto a respective one or more neighboring receivers 203. This too, is a type A channel. In some embodiments similar sensors placed along the spokes 402-404 that connect the gripping member 401 of wheel 400 to the steering column 407 are used to provide detection zones 513-515 in FIG. 3. Similar sensors placed inside steering column 407 of wheel 400 also provide detection zone 516 in FIG. 3, in certain embodiments of the invention.

A third sensor system provides detection zone 501 in FIG. 2. This system includes a row of emitters 104 that project collimated light beams across opening 412 with the aid of collimating light guide 340. A row of receivers (not shown) at the opposite end of opening 412 receives the collimated light beams with the aid of a second collimating light guide 341 embedded in the gripping member 401 of wheel 400. When a driver inserts a hand or finger into the active detection zone 501 in opening 412, he generates a low signal as his hand or finger blocks a portion of the collimated light beams. This is a type B channel.

The illustrated third sensor system features vertical collimated light beams and detects objects along only one axis. In some embodiments, an additional, similar sensor system embedded in the left and right portions of gripping member 401 is added to project horizontal collimated beams across opening 412. In this case, the two sets of orthogonal collimated beams provide two-dimensional (2D) detection of inserted objects. In some embodiments, similar sets of orthogonal beams are used in openings 511 and 512 of FIG. 3 to provide 2D detection as illustrated by light grid 600 in FIG. 4.

A fourth sensor system includes two sensors along each side of steering wheel 400. These sensors provide detection zones 503 and 504 in FIG. 2. Each sensor in this fourth system includes a pair of light guides 310 and 311, as shown in FIGS. 9-11. Light guide 310 is coupled to a transmitter (not shown) and light guide 311 is coupled to a receiver (also not shown). When a driver hovers his hand opposite one of these sensors he generates a high signal as his touch reflects light from light guide 310 back into light guide 311. This is a type A channel. In some embodiments, similar sensors are placed around the entire wheel to provide detection zone 517 in FIG. 3.

A fifth sensor system includes a series of sensors along the upper outer rim of steering wheel 400. These sensors provide detection zone 502 in FIG. 2. Each sensor in this fifth system includes a transmitter 100, a receiver 200 and a light guide 300. A driver touching the outer rim of the wheel opposite one of these sensors generates a high signal as his touch reflects light from emitter 100 back onto receiver 200. Therefore this is a type A channel. Similar sensors placed around the entire wheel can be used to provide detection zone 22 in FIG. 3.

In some embodiments of the present invention, in addition to the near-infrared light used for the sensors, visible light elements are also embedded in the steering wheel, to light up the various detection zones. The visible light elements are used, inter alia, in order to illuminate a hand inside zones 510-512, or to follow hand movements inside zones 510-512 or along zones 502-506, so as to provide visible feedback to the driver who is interacting with the sensors.

The type A channel sensor systems described hereinabove detect light from the transmitter reflected off the driver's finger or hand onto a nearby receiver. The maximum distance that this type A sensor can detect is defined as the sensor's "nominal range". In some embodiments, the different sensor systems have different nominal ranges. For example, when the second and fifth sensor systems are designed to be used as a touch switch or slider control, they are adjusted to a very short nominal range. Similarly, when the first and fourth sensor systems are designed to detect hover gestures in the air above or opposite the sensor, they are adjusted to a nominal range of several inches. And when the first system is designed to detect a driver entering the car it is adjusted to a very large nominal range.

There are several ways to adjust the nominal range, based inter alia on the intensity of the transmitter, on the detection threshold used to decide whether an object is present in the channel, and on the light guide. Specifically, when the light guide absorbs a portion of the light in the detection channel the sensor has a shorter nominal range.

The first sensor system, used for detection zones 507 and 508, is now addressed in detail.

Reference is made to FIGS. 12-16, which are simplified diagrams of proximity sensors on a steering wheel, in accordance with an embodiment of the present invention. FIGS. 12-15 show layers of components that form sensors 520 and 521. FIG. 12 shows proximity sensors 520 and 521 as seen by a driver. FIG. 13 shows proximity sensors 520 and 521 with the upper steering wheel casing layer removed. As seen in FIG. 13, these proximity sensors feature a supporting column 332 having a transmitter light guide upper surface 333 and a receiver light guide upper surface 334 at the top of the column. In FIG. 14 column 332 is removed, exposing upward facing transmitter 101 directly beneath light guide 330, upward facing receiver 201 directly beneath light guide 331, and light barrier 335 between transmitter 101 and receiver 201 to prevent scattered light from transmitter 101 from reaching receiver 201. FIG. 15 is another view of the elements in both proximity sensors 520 and 521: transmitters 101 and 102, receivers 201 and 202, light guides 330, 331, 336 and 337 and light barriers 335 and 338. Light guides 330, 331, 336 and 337 are adapted to use total internal reflection (TIR) to maximize the amount of light in this detection channel.

The operation of sensors 520 and 521 is illustrated in FIG. 16 showing emitter 101 sending a direct light beam 601 and a TIR beam 602 through light guide 330 out above the sensor. A finger 413 hovering above the sensor reflects a portion of the emitter beam back into neighboring light guide 331 and onto receiver 201, as illustrated by two-sided arrow 603. Light guide 331 and receiver 201 are not shown in FIG. 16.

The second sensor system, adjusted to a very short nominal range and used for zones 502, 505 and 506, is now addressed in detail.

Reference is made to FIGS. 17-20, which are simplified illustrations of slider controls embedded in a steering wheel, in accordance with an embodiment of the present invention. FIGS. 17-20 show layers of components that form slider controls 522 and 523. In the illustrated embodiment each of these slider controls is situated inside a gently sloping recessed cavity to facilitate gliding a finger along the control without taking eyes off the road. A first recessed cavity is formed by inclined surface 417 surrounded on three sides by walls 414-416. Slider control 523 is located along the boundary joining surface 417 to wall 415.

FIG. 18 shows that the exposed surface of slider controls 522 and 523 is the long, thin, top surface of upright light guides 320 and 321. Light guides 320 and 321 are supported

in their upright position by being inserted through narrow opening slots 419 in intermediate layer 418.

FIG. 19 shows the inner components of slider control 522 after intermediate layer 418 has been removed. Slider control 522 includes one alternating row of transmitters 103 and receivers 203, and one upright light guide 320. Slider control 522 is a linear series of detection channels where each channel has a transmitter at one end of the channel and its neighboring receiver in the alternating row of transmitters and receivers at the other end of the channel.

Reference is made to FIG. 20 illustrating the light beam path through this channel. Light beam 604 exits transmitter 103 and is directed upward through light guide 320. A finger 413 touching the top of light guide 320 reflects a portion of the beam back down into light guide 320. A portion of this reflected light is directed through light guide 320 onto a neighboring receiver 203 (shown in FIG. 19) completing the detection channel. As a driver's finger glides along the exposed surface of light guide 320 different detection channels are activated indicating the location of the finger along this slider control. Light guides 320 and 321 are adapted to use TIR to maximize the amount of light in the detection channels.

The type B sensor system used for zone 501 will now be discussed in detail.

Reference is made to FIGS. 21-30, which are simplified diagrams of sensors embedded in a steering wheel that detect gestures inside an open cavity in the steering wheel, in accordance with an embodiment of the present invention. Detection zone 501 is illustrated in FIG. 21. FIG. 22 shows the exposed upper edge 342 of light guide 341 that projects light beams into zone 501. FIG. 23 shows a rotated cross section of light guide 341 and an array of transmitters 104 situated below light guide 341 in the steering column. Light guide 341 includes collimating, internally reflective elements (not shown) that collimate light inside the light guide, internally reflective facet 344, and curved window 345. Curved window 345 is required in order that this light guide follow the contours of the rounded steering column in which it is mounted. The outer surface of window 345 is exposed upper edge 342 of FIG. 22. In some embodiments of the present invention, window 345 is formed with a uniform thickness, in order to minimize the lens effect that this window has on the sensor light beams. In some embodiments, window 345 is also formed as thin as possible, in order to minimize the distance that the light beams are shifted laterally when they pass through the window.

Reference is made to FIG. 24 showing light guide 341 viewed from underneath. In this view, internally reflective collimating surfaces 343 are visible. Each surface 343 collimates a wide light beam emitted by a transmitter into the light guide. In addition, surface 343 also redirects the collimated light onto internally reflective surface 344 as light beam 605 in FIG. 25 illustrates.

FIG. 26 shows three beams 606-608 from respective emitters 106-108, passing through lens 345. FIG. 26 illustrates how a uniform thickness and a large radius of curvature relative to the width of the beam of window 345, minimize the lens effect on three light beams 606-608. E.g., beam 606 is offset to the left of emitter 106 when it exits curved window 345, but is not redirected as a result of passing through the window. The offset for beam 606 is indicated in the figure by distance 420. When window 345 is thin, the offset is negligible. In some embodiments, for which the offset is not negligible and for which the emitters and receivers are evenly spaced on PCB 411, beam offsets are handled in software, inter alia by calculating the position of the corresponding

blocked beam according to the beam position when it crosses the screen, which is offset from the emitter and receiver location. In other embodiments, for which the offset is not negligible, the emitters and receivers are not evenly spaced on PCB 411, in order for the offset to cause the beams crossing detection zone 501 to be evenly spaced. The dotted portions 610 of the beams represent the beams passing through light guides 340 and 341, which are not shown in this figure.

The second half of the light sensor for zone 501 is now discussed. FIG. 27 shows the exposed lower edge 346 of a light guide that receives the projected light beams and directs the beams onto receivers embedded inside the circular gripping member of the steering wheel. FIGS. 28 and 29 are two cross-sectional views showing three staggered rows of receiver elements 204 together with their respective light guides inside the circular gripping member of steering wheel 400. Collimated light crossing detection zone 501 enters the gripping member through curved window 353. In order to maintain the collimation of the light beams, window 353 has a uniform width and substantially similar arcs at both its inner and outer surfaces, like window 345 described hereinabove.

FIG. 29 shows light guide 340 from a different angle than in FIG. 28. The collimating portion of this light guide is circled section 347. This collimating portion uses two air-to-plastic interfaces to direct the collimated wide beam onto a respective receiver 204. The operation of these collimating lenses is more fully explained in U.S. patent application Ser. No. 13/424,543 for OPTICAL ELEMENTS WITH ALTER-NATING REFLECTIVE LENS FACETS, the contents of which are incorporated herein by reference. In particular, reference is made to FIGS. 50-52 and associated paragraphs [00267]-[00271] in U.S. patent application Ser. No. 13/424,543. In the embodiment illustrated in FIG. 29 the light guides are formed of a single piece of plastic 348. The receivers 204 are shown suspended in cavities 421 formed in plastic 348. The PCB on which these receivers are mounted is not shown in the figure: it is above the receivers, and covers cavities 421. The path of a light beam 611 through light guide 340 is shown.

Light transmitters and receivers for two different sensors are mounted on two sides of PCB 411. FIG. 30 shows exploded views from both sides of steering wheel PCB 411. The light receivers 204 for detection zone 501 are on one side of the PCB, and transmitter-receiver pairs 100-200 for detection zone 502 are mounted on the reverse side of this PCB. The exploded view also shows light guide 300, used for detection zone 502, and plastic element 348 that forms light guide 340, both mounted on PCB 411.

The type A sensor used for detection zones 503 and 504 described hereinabove will now be described in detail.

Reference is made to FIGS. 31-35, which are simplified diagrams of proximity sensors embedded in the outer rim of a steering wheel, in accordance with an embodiment of the present invention. FIG. 31 shows four detection zones 524-527 on either side of steering wheel 400. FIG. 32 shows two of the sensors that provide these detection zones on one side of the steering wheel by projecting light beams away from the wheel and detecting a portion of the beams that is reflected back by a hovering finger or hand. As seen by the driver, each sensor includes a light emitting surface 354 or 356, and a neighboring light receiving surface 355 or 357. FIG. 33 shows a plastic rim 422 inlaid in the outer rim of the steering wheel and having near-infrared (NIR) transmissive portions 354-357 that allow the passage of NIR light for these sensors. FIG. 34 shows that the NIR transmissive portions are actually separate light guides 358-361, where a pair of light guides forms a detection channel. Each of light guides 358-361 is

coupled to a respective transmitter or receiver component. Thus, light guides 358 and 360 are coupled to respective transmitters (blocked from view in the figure by light guides 359 and 361), and light guides 359 and 361 are coupled to receivers 209 and 210, respectively. FIG. 35 shows a light beam path 612 through light guide 358. FIG. 35 also shows transmitter 109 coupled to light guide 358.

Reference is made to FIGS. 36-38, which are simplified diagrams of touch sensors embedded across the outer rim of a steering wheel, in accordance with an embodiment of the present invention. FIGS. 36 and 37 show the components in a type A sensor used for detection zone 502 described hereinabove; namely, transmitter-receiver pairs 100-200 and light guide 300. Light guide 300 is shared by both transmitter 100 and receiver 200, and light guide 300 has a collimating lens portion 362 opposite each transmitter and opposite each receiver. FIG. 38 shows how light guide 300 acts as a periscope for the light beams, such as light beam 613 emitted by emitter 100. As described above, a steering wheel equipped with a series of these sensors along its outer rim is enabled to detect tap gestures and hand-slide gestures along the wheel's outer rim.

In some embodiments of the present invention, a processor connected to the touch sensors along the steering wheel rim or spokes detects the number of fingers on each hand touching the wheel. This is performed by heuristically determining the size of the segment covered by a hand holding the wheel, or by detecting a series of up to four objects next to each other along the sensor array. When the driver taps the wheel with only one finger as he grips the wheel, e.g., by tapping on the wheel with one finger while continuing to grip the wheel with the other fingers, the processor determines which finger performed the tap according to the location of the tap within the segment of the wheel being held. This enables a user interface whereby different fingers are associated with different functions. For example, taps by an index finger control the stereo and taps by the middle finger control the telephone. Determination of which finger is tapping the wheel is based on the finger's relative position within the segment of the wheel that is held, as detected by the touch sensors. As such, this user interface is not dependent on which segment of the wheel is being touched. It is thus applied anywhere on the wheel, based on relative finger position. In some cases, the processor distinguishes between right and left hands according to right and left halves of the wheel.

In some embodiments of the present invention, multiple sensors are arranged around the tubular or cylindrical surface of the wheel grip in order to detect when the driver rotates his hand around the grip in the manner of a motorcycle driver revving a motorcycle engine by rotating the handle bar grip. The user interface is configured to control a particular feature by this gesture. In applications of the present invention to motorcycle handlebars, these sensors provide an alternative to rotating handlebar grips for controlling the speed of the motorcycle engine.

In some embodiments of the present invention, proximity detectors or touch detectors are also mounted on the rear of the steering wheel grip or spokes to detect tap gestures on the back of a spoke or on the back of the wheel grip performed by fingers wrapped around the wheel. For example, these gestures are used to shift gears, or to shift the drive mode. Drive modes include, inter alia, eco mode, sport mode, 2-wheel drive and 4-wheel drive.

In some embodiments of the present invention, the vehicle loads a user profile that configures the user interface, including assigning various gestures to respective control settings. The vehicle supports multiple users by allowing each user to

download his settings to the vehicle. Thus, settings for multiple users are uploaded to an Internet server. When a driver enters a car, the driver downloads his settings from the Internet server to the vehicle, thus adapting the vehicle to his customized settings. For example, different gestures can be mapped to control different features by the driver. One application for this system is a rental car. When a driver rents a car he downloads his user profile to the rental car so that the user interface is familiar. Another application is for car dealerships, whereby a car's user interface is customized for a buyer while the buyer tries out a test model or sits inside a dummy cockpit. The dealer configures the user's profile in the demo car and uploads it to the Internet server. The dealer does not need to customize the purchased car when it arrives beyond downloading the buyer's profile.

Aspects of the present invention also relate to contextual user interfaces. When a driver enters the car, the car's user interface asks the driver what he wants to do and guides him to do so, using a display screen. Thus the UI presents options based on context. If the engine is off, the UI asks if the driver wants to start the car. If the driver turns off the motor, the UI presents the following initial options: open doors, open gas tank, open trunk, and open hood. In some embodiments, the display renders a map of the different hand slide and tap gestures that the driver can perform on the steering element to execute these options. If the driver stops the car, the UI asks if the driver wants to park. If the driver responds that he does wish to park, the UI presents parking options, e.g., park on the street or in a nearby lot. In an automated car, capable of traveling without a driver, the UI offers the further option to refill gas, battery or solar panel (depending on how the car is powered) while the driver is out shopping or working. Before leaving the car, the UI asks the driver when to return to the parking spot.

In some embodiments, a biometric sensor is also added to the steering element of the present invention. In order to access the UI, the biometric sensor must first register the driver. If the biometric sensor detects that the driver is not fit to drive the car, e.g., the sensor detects a high heart rate or high alcohol content, the UI responds accordingly and does not allow the driver to drive.

Another embodiment of a steering wheel according to the present invention is illustrated in FIGS. 39-42. In this embodiment, the steering wheel includes two embedded touch-sensitive display screens. The display screen information is displayed on a head-up display to the driver so that the driver need not remove his eyes from the road to look down at the displays.

Reference is made to FIG. 39, which is a simplified illustration of a steering wheel with multiple touch sensors and embedded touch screen displays, in accordance with an embodiment of the present invention. FIG. 39 shows steering wheel 400 having two embedded touch screens 450 and a slider control 530. Slider control 530 is implemented as a series of light emitters and receivers similar to slider controls 522 and 523 described hereinabove with reference to FIGS. 17-20. Touch screens 450 are touch-enabled by a series of emitters and receivers along the screen edges that form a touch-detection light grid that covers each screen 450. Steering wheel 400 is also shown having two proximity sensor strips 531 and 532 for detecting a driver's hand placed on the steering column between these two strips.

Reference is made to FIG. 40, which is a simplified illustration of the steering wheel of FIG. 39 with a head-up display, in accordance with an embodiment of the present invention. FIG. 40 shows steering wheel 400 viewed at an angle. Two head-up displays 451 are provided for rendering graph-

ics from screens 450 at a location easily viewable by the driver. The driver can interact with a user interface on screens 450 by viewing head-up displays 451 and performing touch gestures on screens 450.

Reference is made to FIGS. 41 and 42, which are simplified illustrations of proximity sensors that line the steering column of the steering wheel of FIG. 39, in accordance with an embodiment of the present invention. FIG. 41 shows that the front and top of steering column 407 is touch sensitive by virtue of two strips of proximity sensors. A first proximity sensor strip 531 is shown. This strip is formed by an alternating series of emitters and detectors that emit light beams across the outer surface of column 407. This strip curves along the contours of steering column 407. When the driver places his hand on steering column 407, the hand reflects the projected light beams back into the proximity sensor where neighboring detectors sense an increase in reflected light. The operation of this type of proximity sensor is described in applicant's co-pending U.S. patent application Ser. No. 13/775,269 entitled REMOVABLE PROTECTIVE COVER WITH EMBEDDED PROXIMITY SENSORS, especially FIGS. 4-10 there. The second proximity sensor strip 532 is opposite strip 531 and is not visible given the viewing angle of FIG. 41.

FIG. 42 shows the light beams of proximity sensor strip 531. Emitter beams 614 are shown adhering to the contours of steering column 407. One reflected beam is shown as dashed beam 615. When the driver places a hand on steering column 407 his hand reflects one or more of beams 614 back as beam 615.

Reference is made to FIG. 43, which is a simplified illustration of a user interface gesture performed on the steering column of the steering wheel of FIG. 39, in accordance with an embodiment of the present invention. FIG. 43 shows a hand gesture detected by the two proximity sensors lining steering column 407. In this gesture the driver tilts palm 452 along the rounded corner formed by steering column 407. In some applications, this gesture is used to adjust the angle of a side view mirror. Thus, tilting the palm downward and touching a higher portion of column 407 tilts the mirror upwards; tilting the palm to be more vertical tilts the mirror downward.

The two proximity sensors lining two opposite edges of steering column 407 form a unique two-dimensional detector. A location along the proximity sensor at which the reflected beam is detected is a location along one dimension. The nearer the reflecting object is to strip 531 or 532, the greater the detection signal. Comparing the detection signals of proximity strip 531 to those of proximity strip 532 provides a coarse estimation of where the finger is located between the two strips. Thus, if both strips detect similar amounts of reflected light, the finger is roughly in the middle between the two strips. Whereas if one proximity sensor strip detects more light than the other, the finger is nearer to the high detection strip.

Embodiments of the present invention also relate to vehicle dashboards, driver display systems and related user interfaces.

Reference is made to FIGS. 44-46, which are simplified illustrations of user interfaces and associated sweep gestures that are enabled on a vehicle dashboard, in accordance with an embodiment of the present invention. FIG. 44 shows dashboard display 423 having proximity sensors along its edges. In some embodiments of the present invention, the display itself does not provide touch detection, i.e., it is not a touch screen. A frame 528 is shown surrounding the display. This frame indicates a detection zone for detecting proximity and hover gestures. The display shows two icons 424 and 425 in

the upper right and left corners, each representing a family of related functions. When the driver performs a sweeping gesture with his hand above a portion of the display, he expands a corresponding icon to reveal a complete set of related functions.

FIG. 45 shows the effect of a gesture in this context. Dashboard display 423 is shown in the upper portion of FIG. 45 marked (A). A sweeping gesture across the upper left corner of the display and continuing diagonally across the display is indicated by arrows 426. As the gesture progresses across the screen diagonal, icon 425 expands across the screen. The expanded icon is shown as icon 427 in the lower portion of FIG. 45 marked (B). In some embodiments, this expanded area is populated with icons related to the function represented by icon 425. In other embodiments, the expanded icon presents further options for similar gestures that expand, providing multiple layers of expanded screens.

Embodiments of the present invention thus provide easy access to an extensive array of functions with a simple hand gesture in an associated corner or side of the display. This allows the user interface to present a limited number of icons on the initial display without cluttering up the display, and to expand a selected icon to reveal a full list of related functions in response to the aforementioned sweeping gesture.

FIG. 46 shows dashboard display 423 with four icons 428, 429, 431 and 432 in the four corners of the display and a text box 430 at the right edge of the display. Eight arrows 433-440 indicating eight different sweep gestures are shown. Each sweep gesture changes the display in accordance with an icon or text associated with that gesture. In FIG. 46, gestures 433, 435, 437 and 439 are each associated with a respective icon, and gesture 436 is associated with text 430. Additional gestures such as gliding along the edges of the display also provide functionality in some embodiments.

The hover and proximity sensors that detect the dashboard sweep gestures described hereinabove are substantially the same sensors described with respect to the steering wheel. These sensors are distributed at discrete locations around the dashboard display.

In the foregoing specification, the invention has been described with reference to specific exemplary embodiments thereof. It will, however, be evident that various modifications and changes may be made to the specific exemplary embodiments without departing from the broader spirit and scope of the invention. Accordingly, the specification and drawings are to be regarded in an illustrative rather than a restrictive sense.

What is claimed is:

1. A system for use in a vehicle, comprising:

a steering element, situated opposite a driver's seat in a vehicle, comprising a plurality of proximity sensors for detecting multiple fingers concurrently touching the steering element;

an interactive deck housed in the vehicle, for providing at least one of radio broadcast, video broadcast, audio entertainment, video entertainment, telephone communication and navigational assistance in the vehicle; and a processor housed in the vehicle, coupled with said proximity sensors and said deck, wherein, when said proximity sensors detect that one of the fingers is raised from said steering element, the processor determines which one of the fingers was lifted based on a relative location of the raised finger within the multiple fingers, and wherein the processor performs different functions of said deck in response to similar gestures performed by different thus-determined ones of the fingers.

2. The system of claim 1 wherein said processor identifies the multiple fingers concurrently touching said steering element as being fingers of one hand, based upon the size of a segment covered by a hand holding said steering element.

3. The system of claim 1 wherein said processor identifies the multiple fingers concurrently touching said steering element as being fingers of one hand, by detecting up to four fingers adjacent to one another along a periphery of said steering element.

4. The system of claim 1 wherein said processor controls a radio or an audio function of said deck in response to a tap gesture performed by a first determined finger, and controls a telephone function of said deck in response to a similar tap gesture performed by a second determined finger, different than the first determined finger.

5. The system of claim 1 wherein said processor further determines which of the driver's hands the detected fingers belong to, by associating detections along a left half of said steering element with the driver's left hand, and associating detections along a right half of said steering element with the driver's right hand.

6. The system of claim 5 wherein said processor executes first and second control functions in response to tap gestures performed by index and middle fingers of the driver's left hand, respectively, and executes third and fourth control functions, different than the first and second control functions, in response to tap gestures performed by index and middle fingers of the driver's right hand, respectively.

7. A system for use in a vehicle, comprising:

a steering element situated opposite a driver's seat in a vehicle, comprising a plurality of proximity sensors operable to detect hand gestures along an outer periphery of the steering element;

an interactive deck housed in the vehicle, for providing at least one of radio broadcast, video broadcast, audio entertainment, video entertainment, telephone communication and navigational assistance in the vehicle;

a memory for storing a plurality of different driver tables, each driver table associating each of a plurality of hand gestures with a respective control function for said deck; and

a processor housed in the vehicle, coupled with said proximity sensors, said deck and said memory, operable (i) to select a driver table appropriate for a current driver, (ii) to identify the hand gestures detected by said proximity sensors, and (iii) to execute the deck control functions associated with the thus-identified hand gestures, as per the selected driver table.

8. The system of claim 7 wherein said processor further comprises:

a user identification module for identifying a current driver; and

a communication module for wirelessly communicating with a remote server,

wherein said processor downloads the driver table appropriate for the current driver from the remote server to said memory when the current driver is identified by said user identification module.

9. The system of claim 8 for use in a rental car, wherein the current driver is a renter of the car.

10. The system of claim 8 wherein each driver table is automatically populated by a respective driver interacting with a simulated driver environment outside of an automobile.